

air outlets

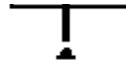

with independent
heating



412-03A-00-501, Air Conditioning, Block diagram Air conditioning without ATC module, 2,0i/2,3i DOHC

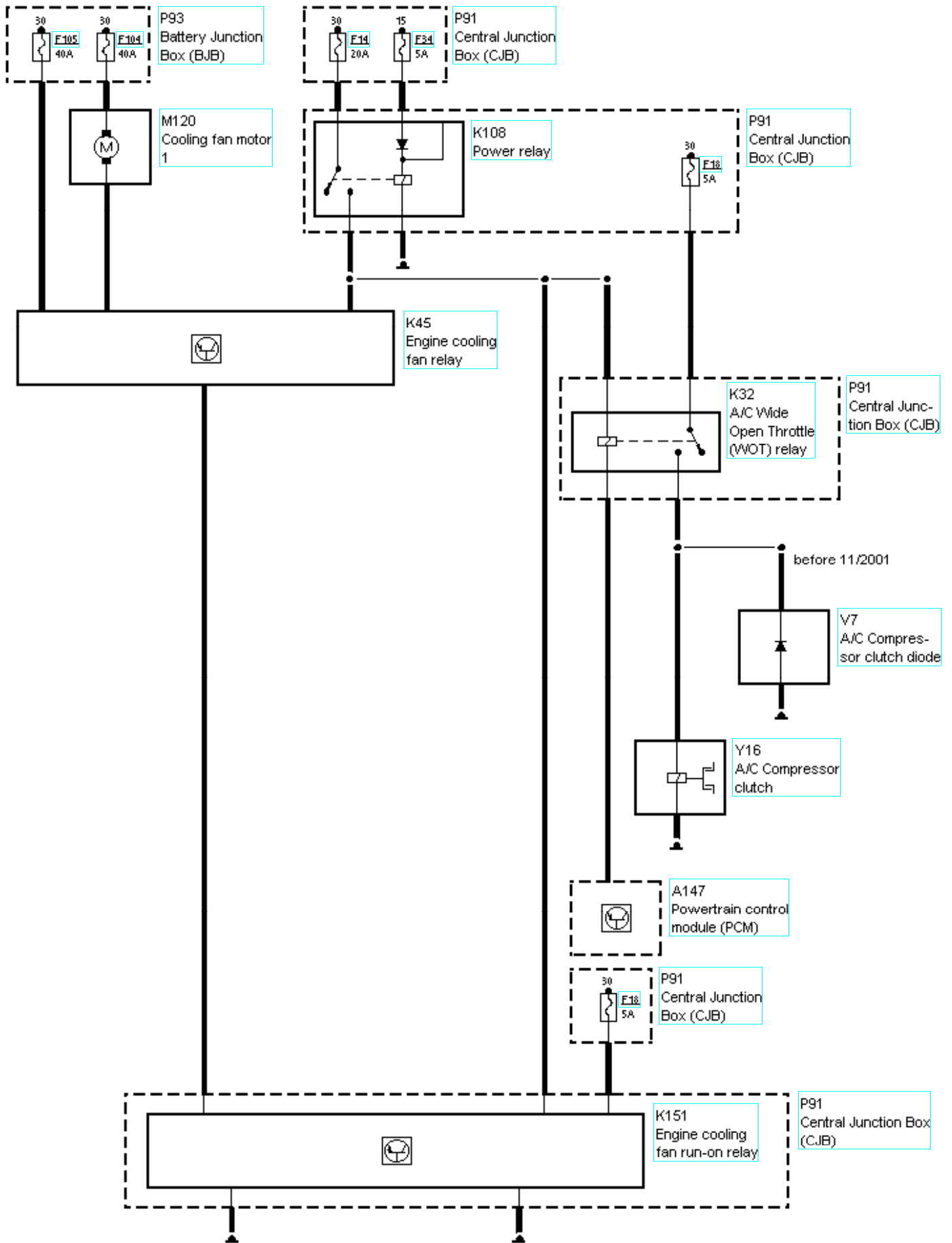

412-03A-00-502, Air Conditioning, Block diagram Air conditioning without ATC module, 2,0i/2,3i DOHC

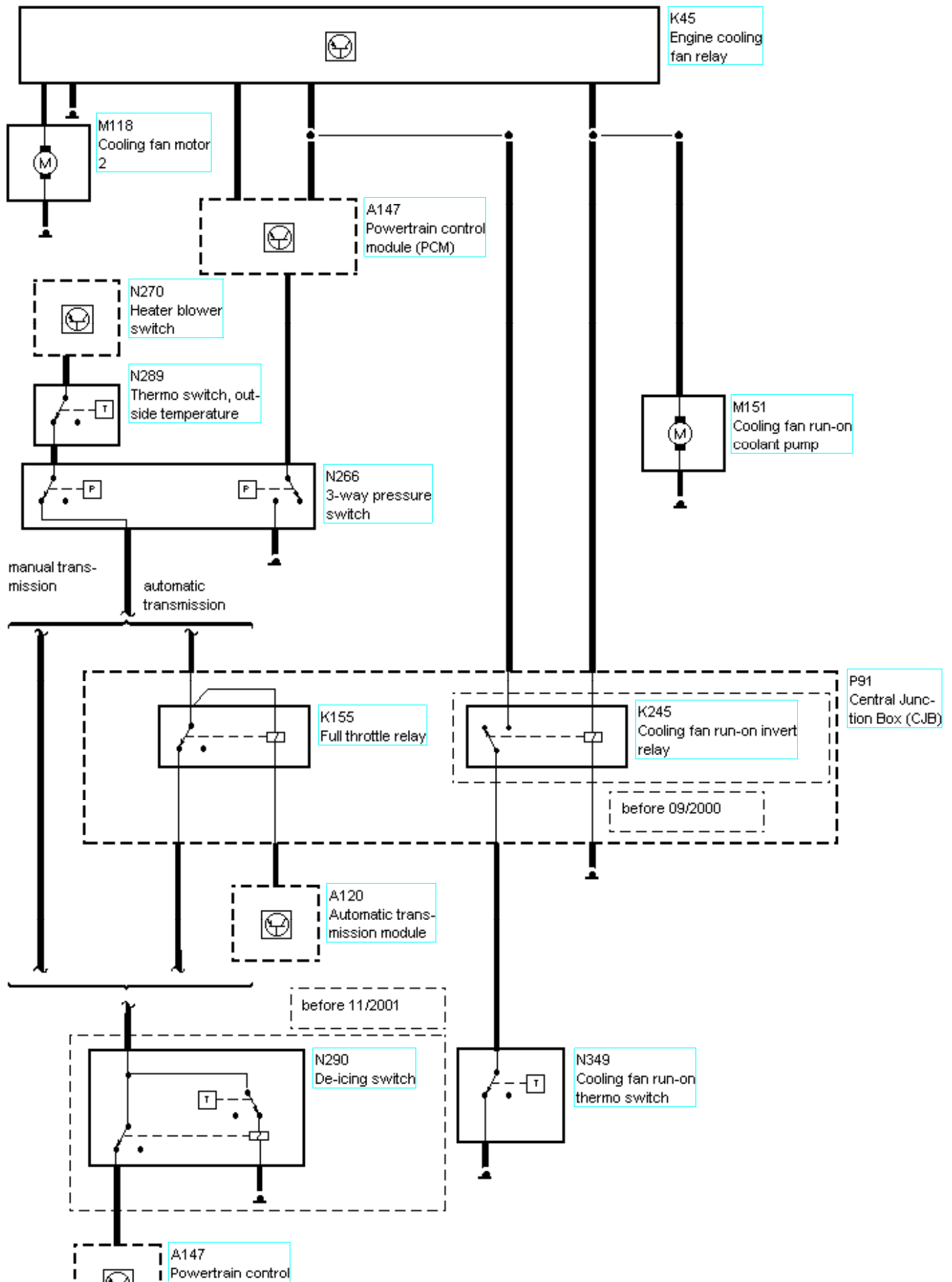

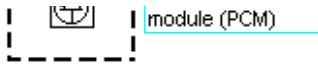

412-03A-00-503, Air Conditioning, Block diagram Air conditioning without ATC module, 2,8i CD-V6 24V, 1,9 TDI unit injector engine, except 1,9 TDI (96kW)

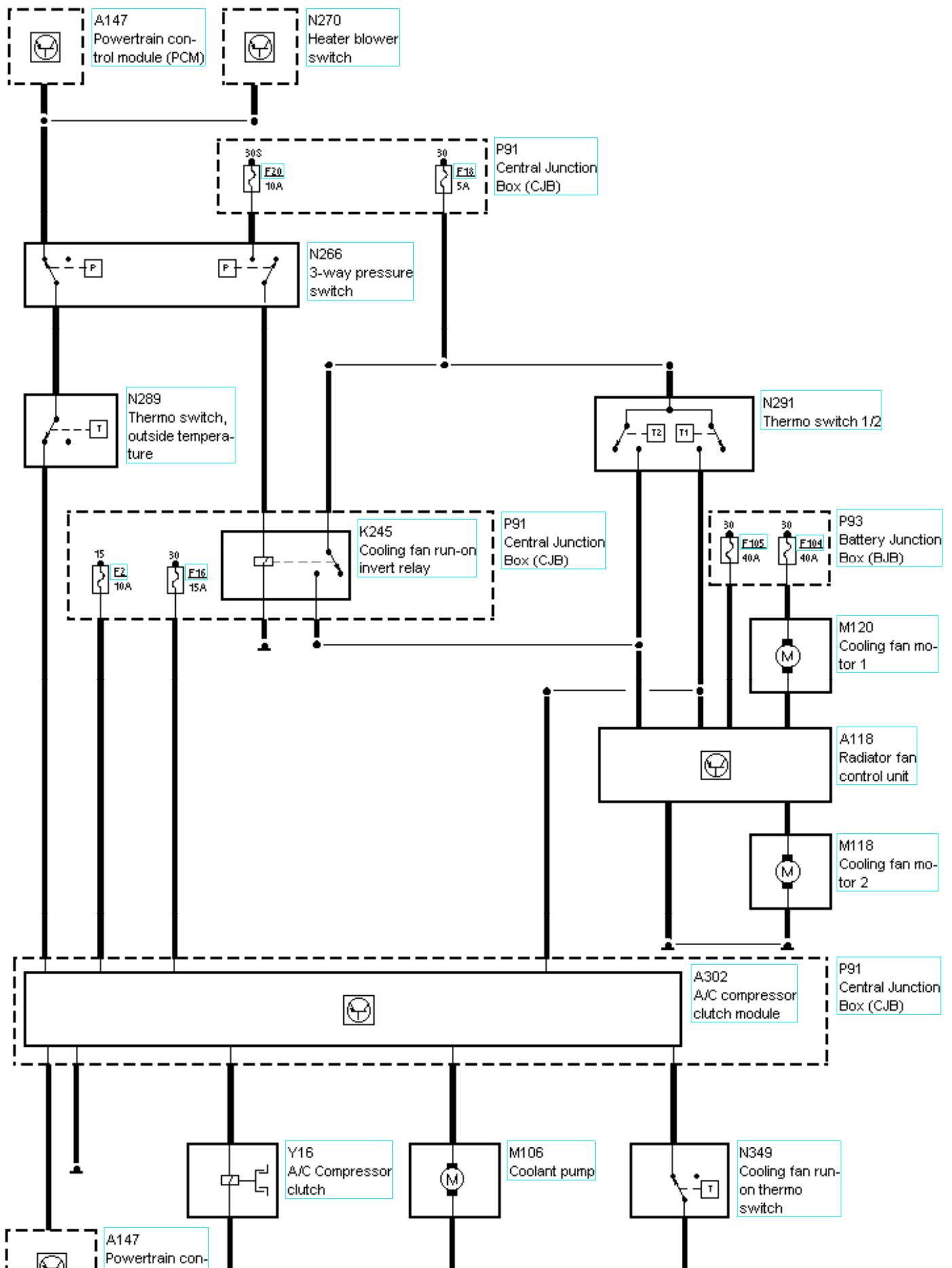

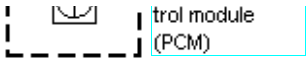

412-03A-00-504, Air Conditioning, Block diagram Air conditioning without ATC module, 1,9 TDI unit injector engine (96kW)

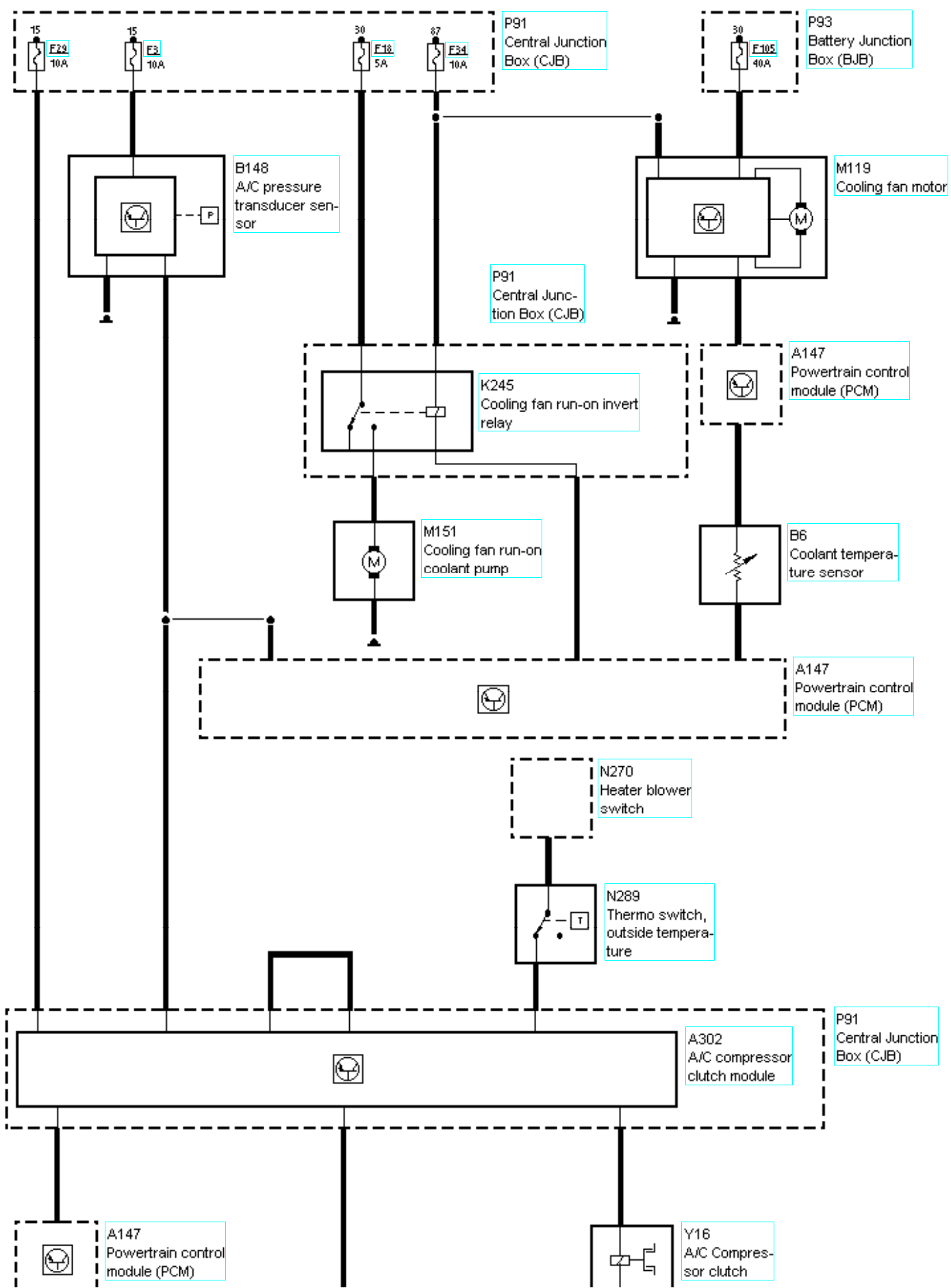

-----:

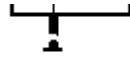

412-03A-00-505, Air Conditioning, Block diagram Air conditioning with ATC module

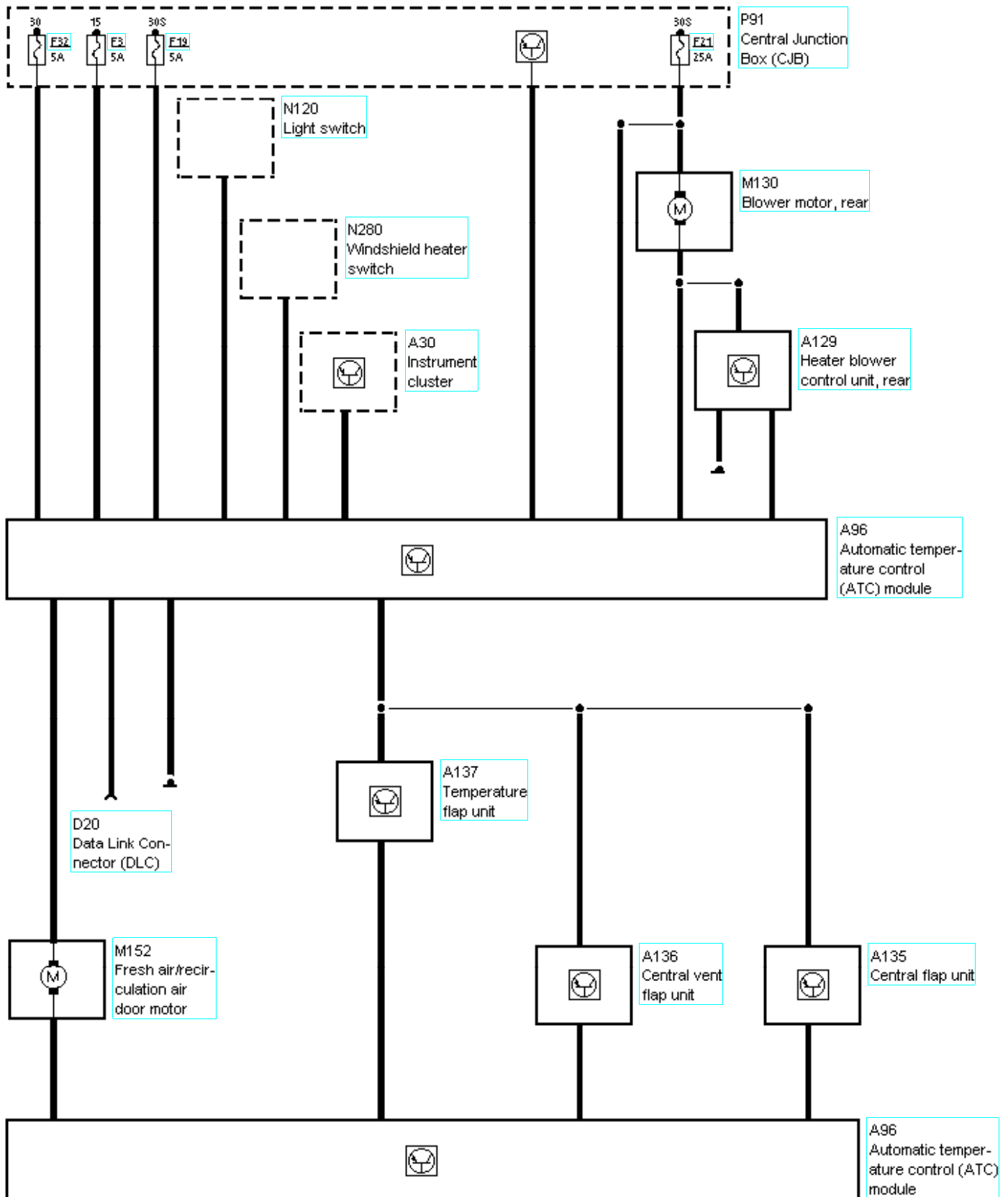

412-03A-00-506, Air Conditioning, Block diagram Air conditioning with ATC module

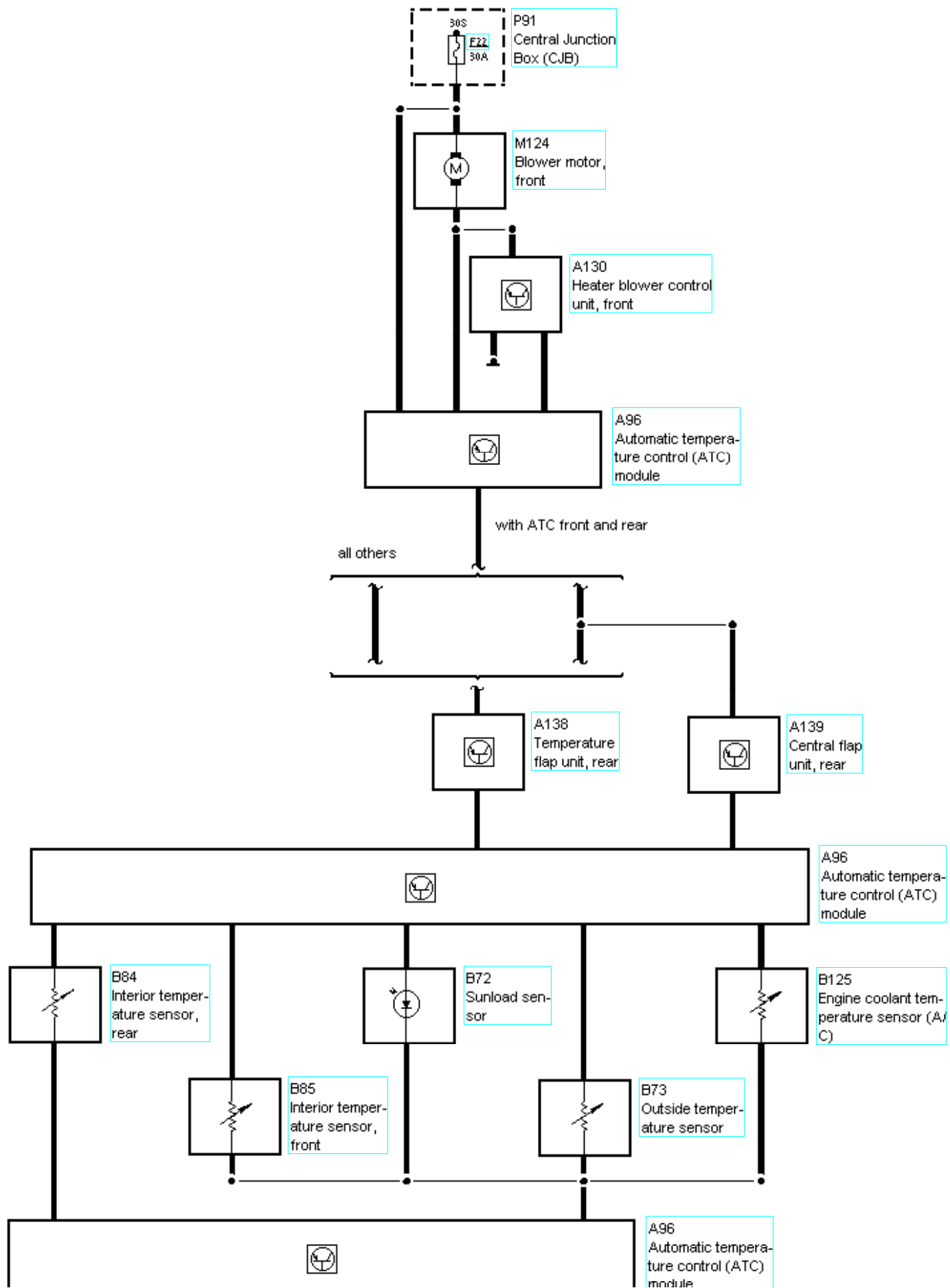

412-03A-00-507, Air Conditioning, Block diagram Air conditioning with ATC module, 2,0i/2,3i DOHC

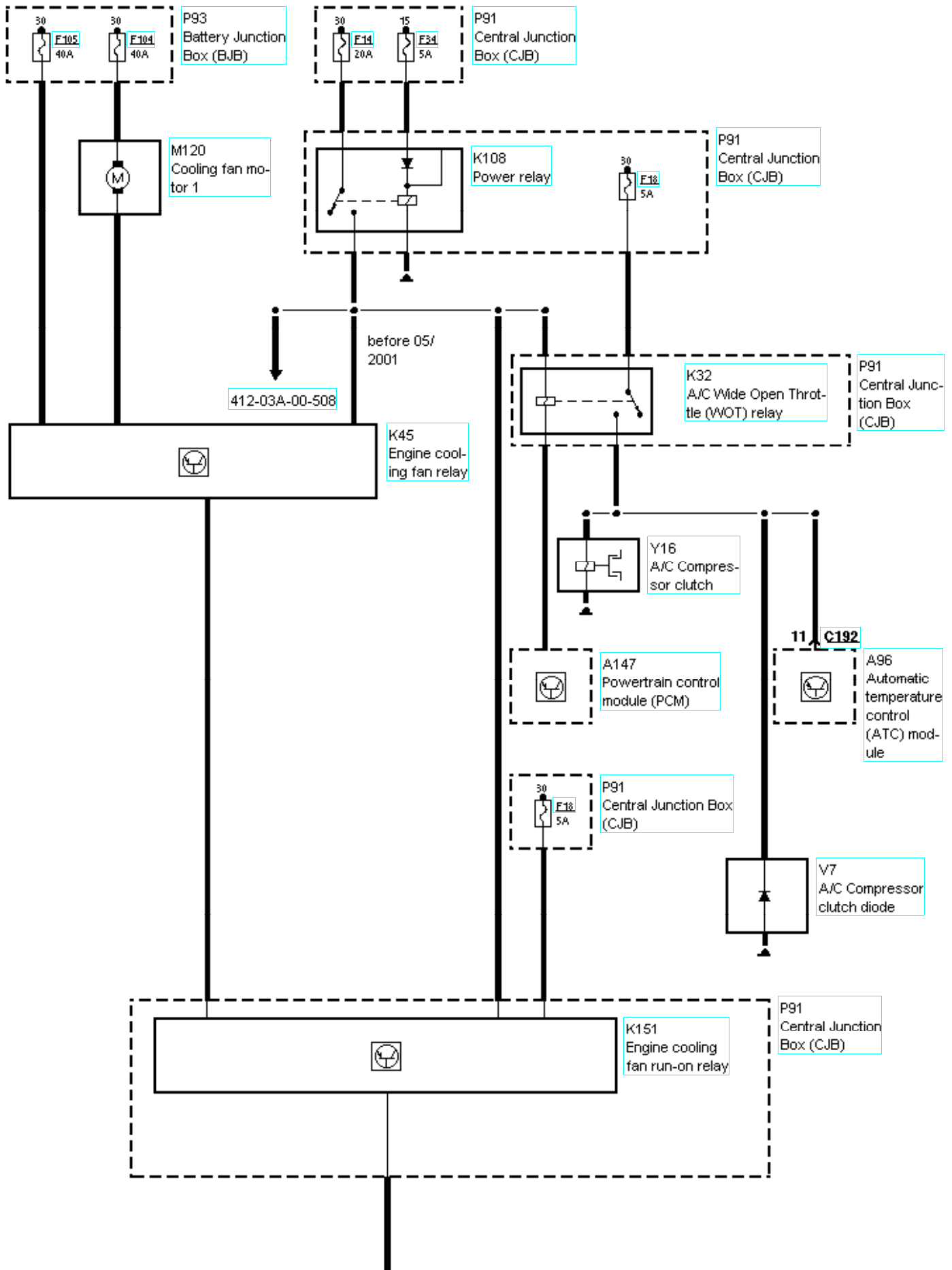



412-03A-00-508, Air Conditioning, Block diagram Air conditioning with ATC module, 2,0i/2,3i DOHC

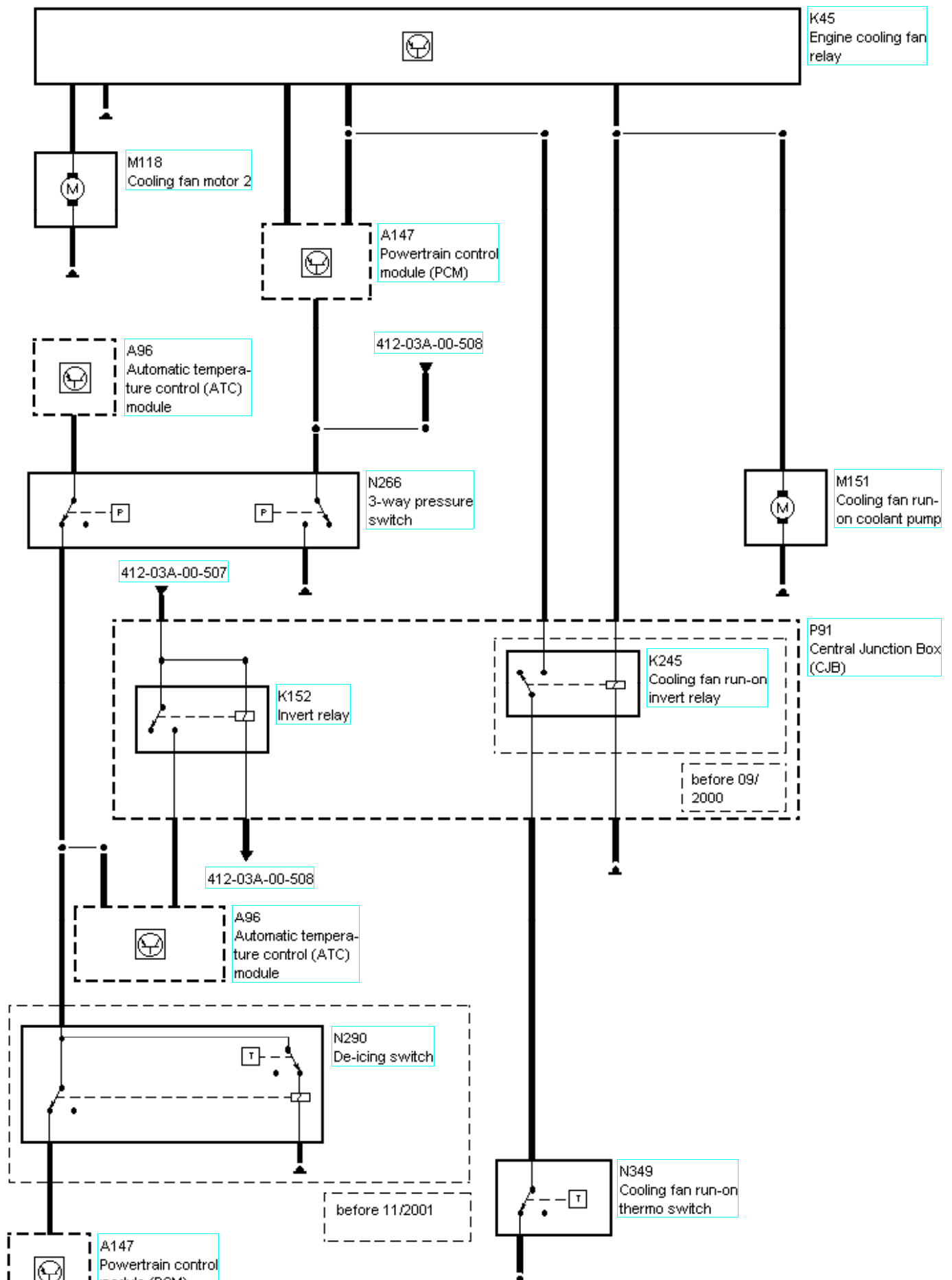

module (PCM)

-

412-03A-00-509, Air Conditioning, Block diagram Air conditioning with ATC module, 2,8i CD-V6 24V, 1,9 TDI unit injector engine, except 1,9 TDI (96kW)

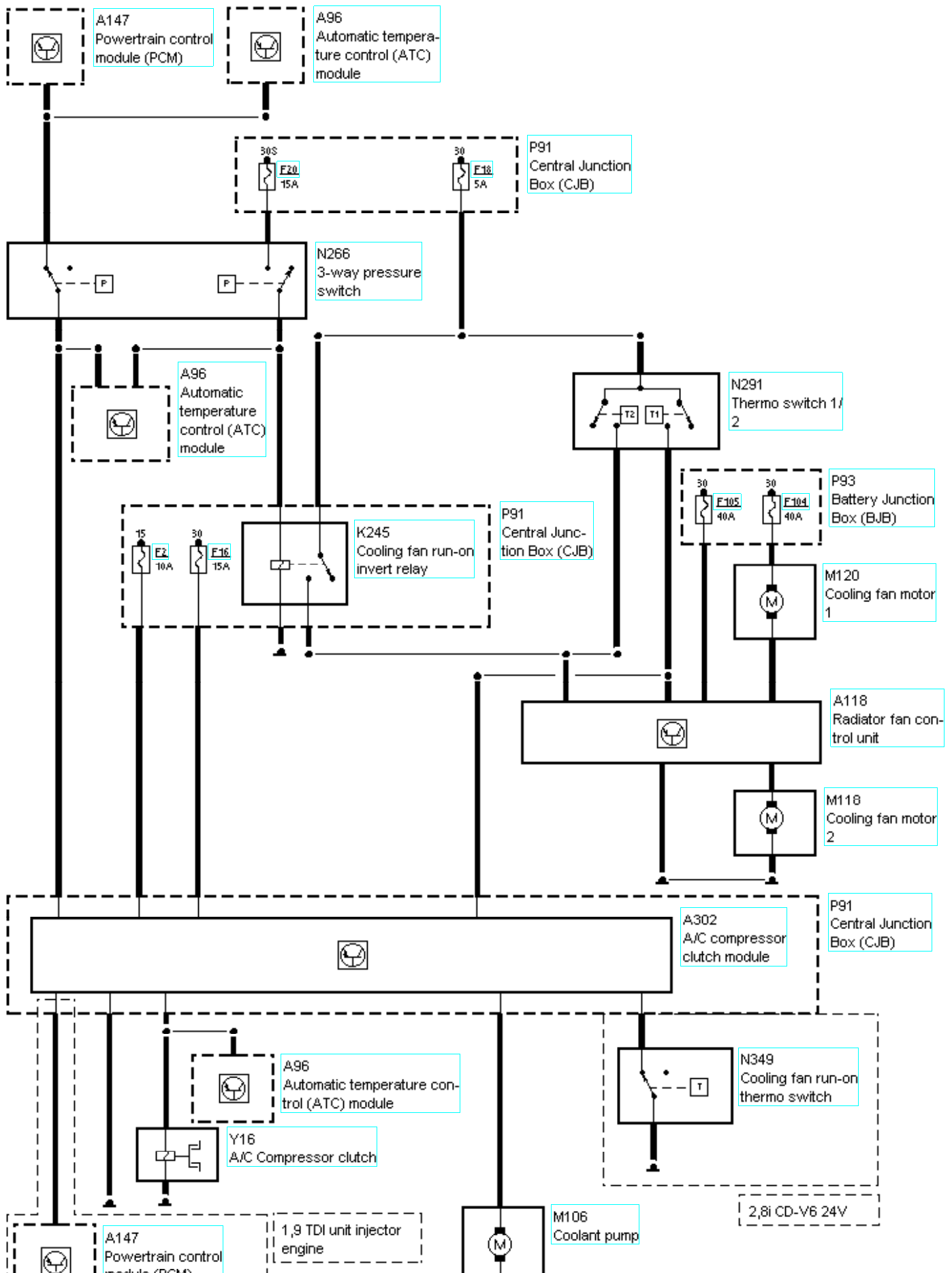

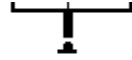
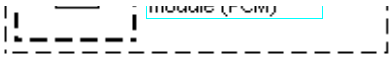

412-03A-00-510, Air Conditioning, Block diagram Air conditioning with ATC module, 1,9 TDI unit injector engine (96kW)

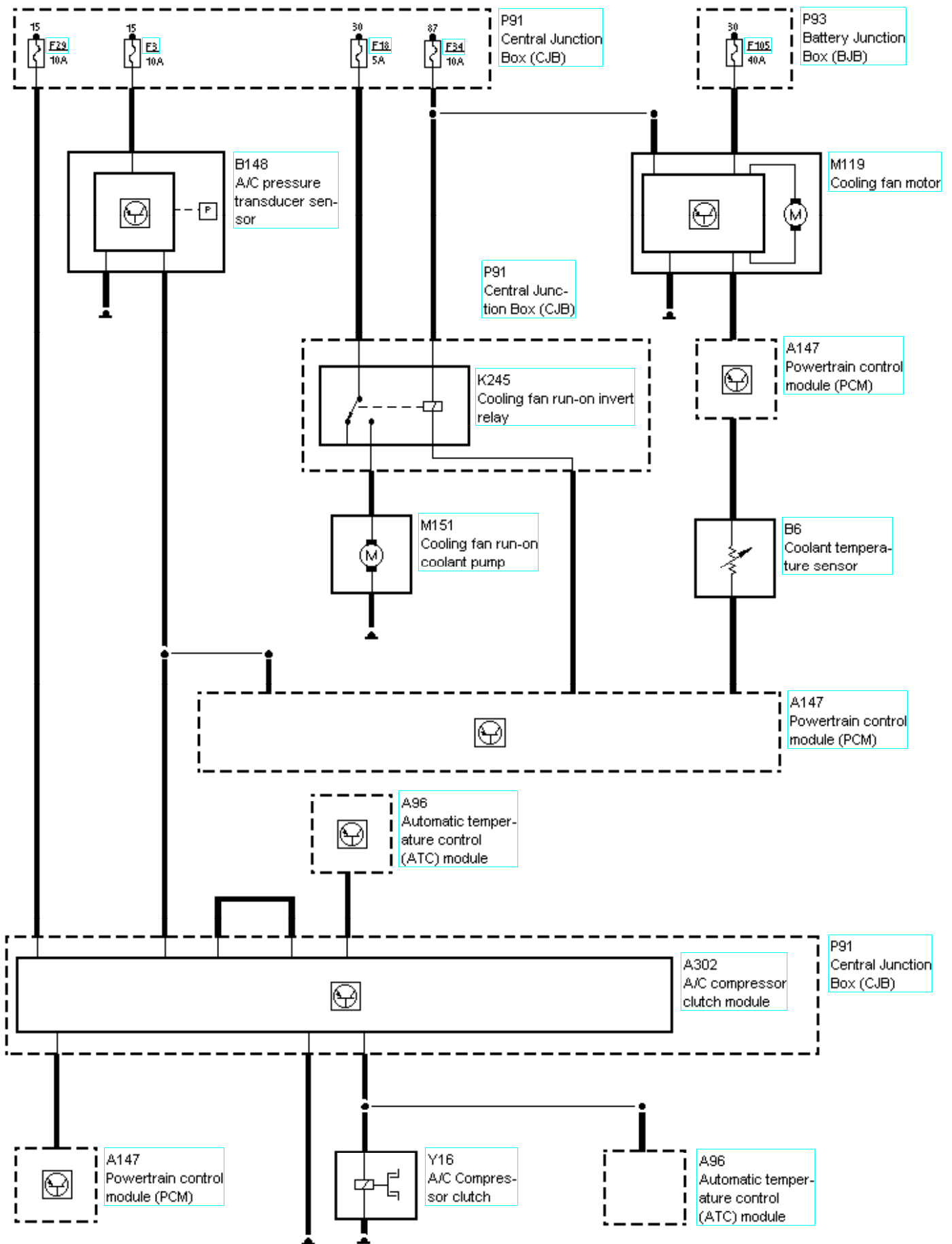

412-03A-00-001, Air Conditioning, Air conditioning without ATC module

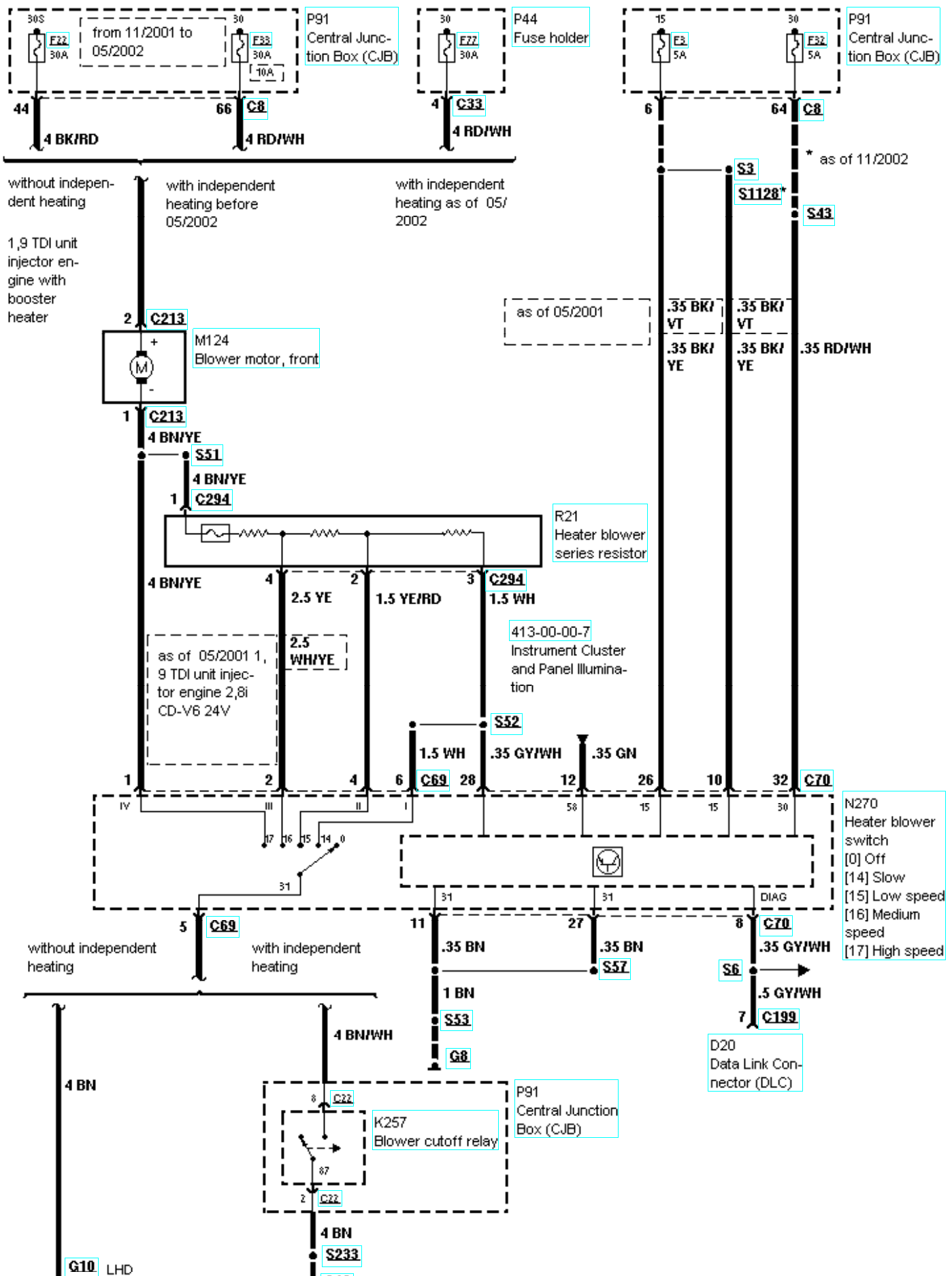

G6 RHD

G19 LHD
G6 RHD

412-03A-00-002, Air Conditioning, Air conditioning without ATC module

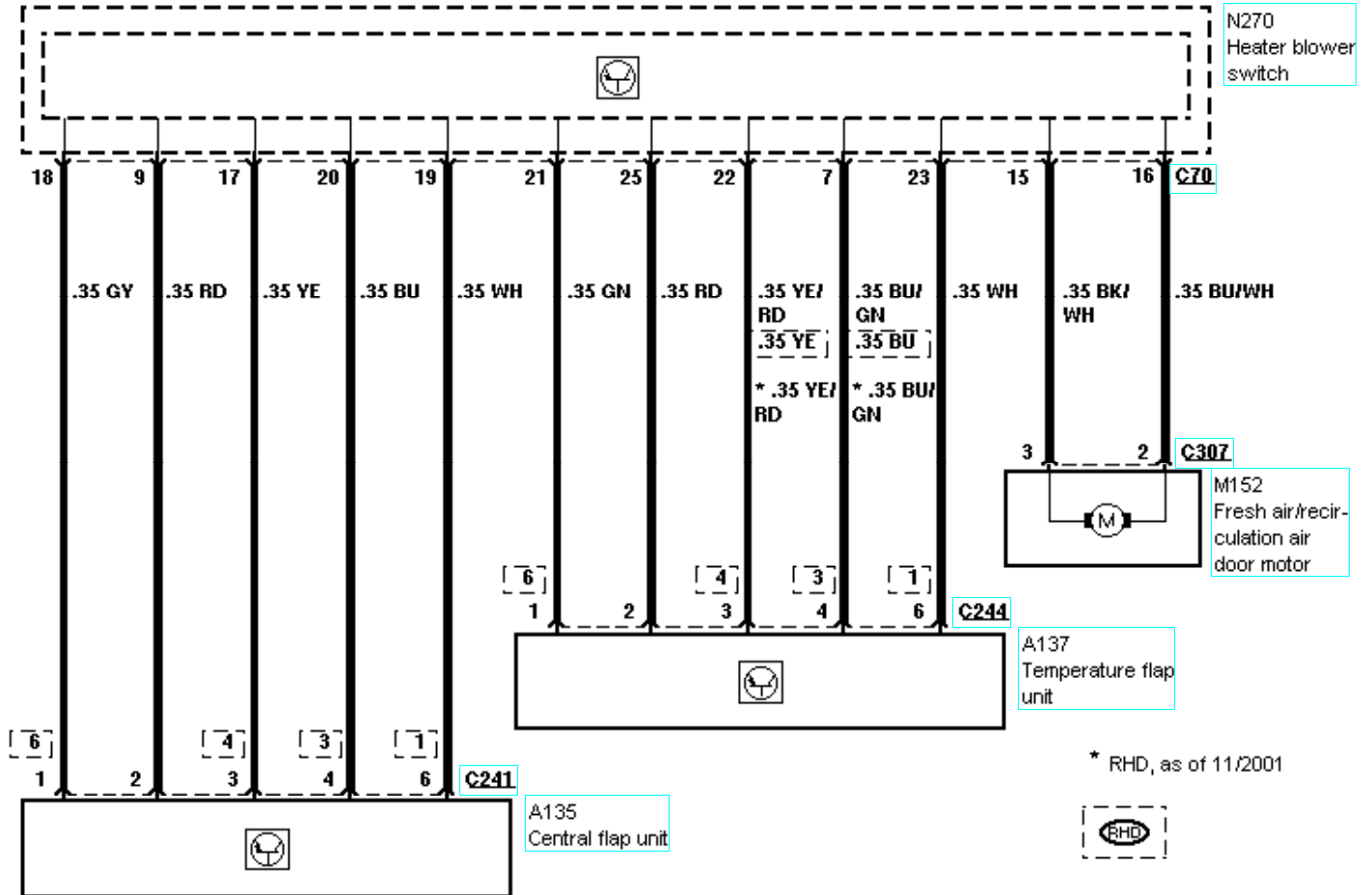

412-03A-00-003, Air Conditioning, Air conditioning without ATC module

412-03A-00-004, Air Conditioning, Air conditioning without ATC module, 2,0i/2,3i DOHC before 09/2000

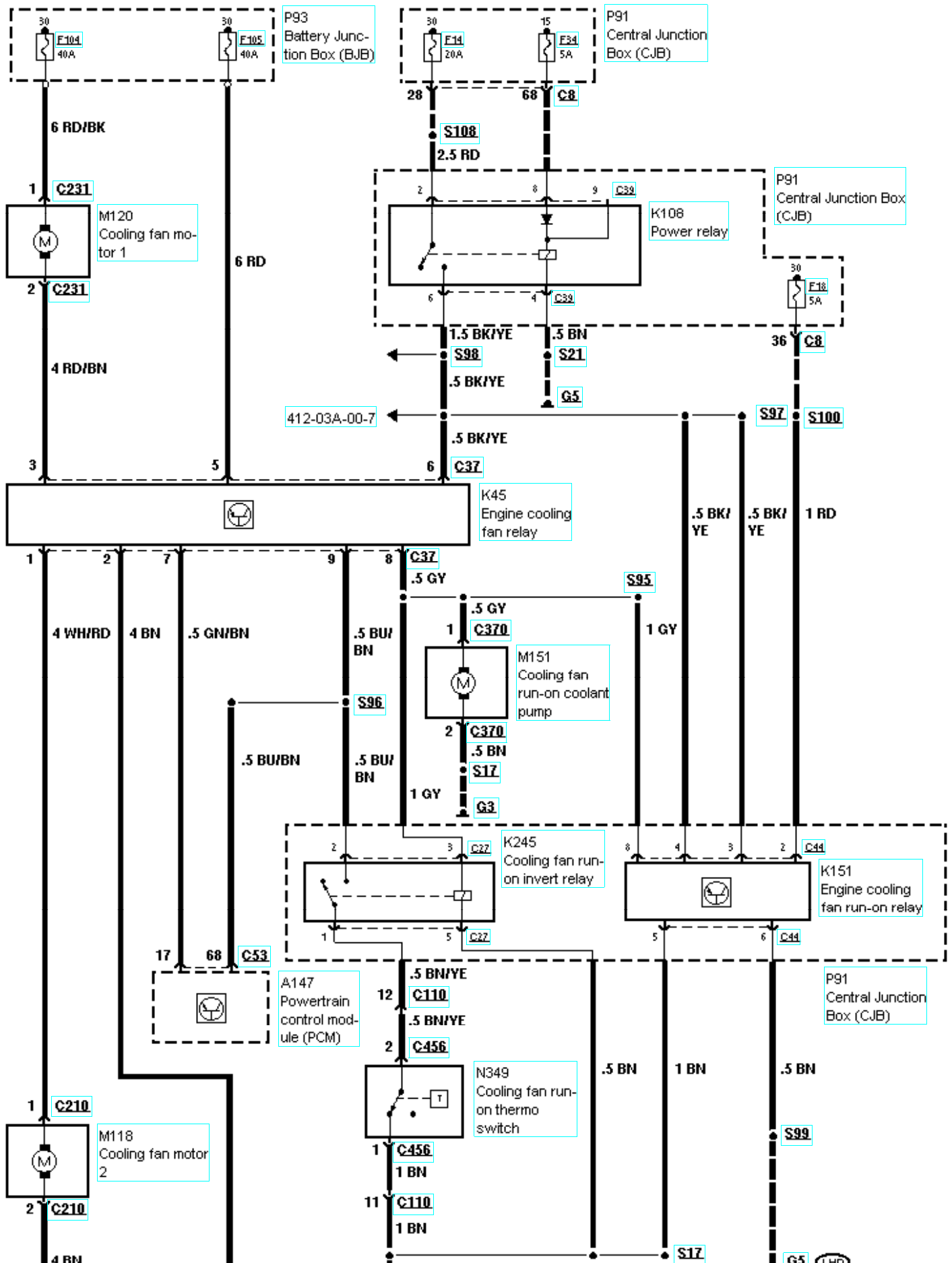



412-03A-00-005, Air Conditioning, Air conditioning without ATC module, 2,0i/2,3i DOHC, from 09/2000 to 05/2001

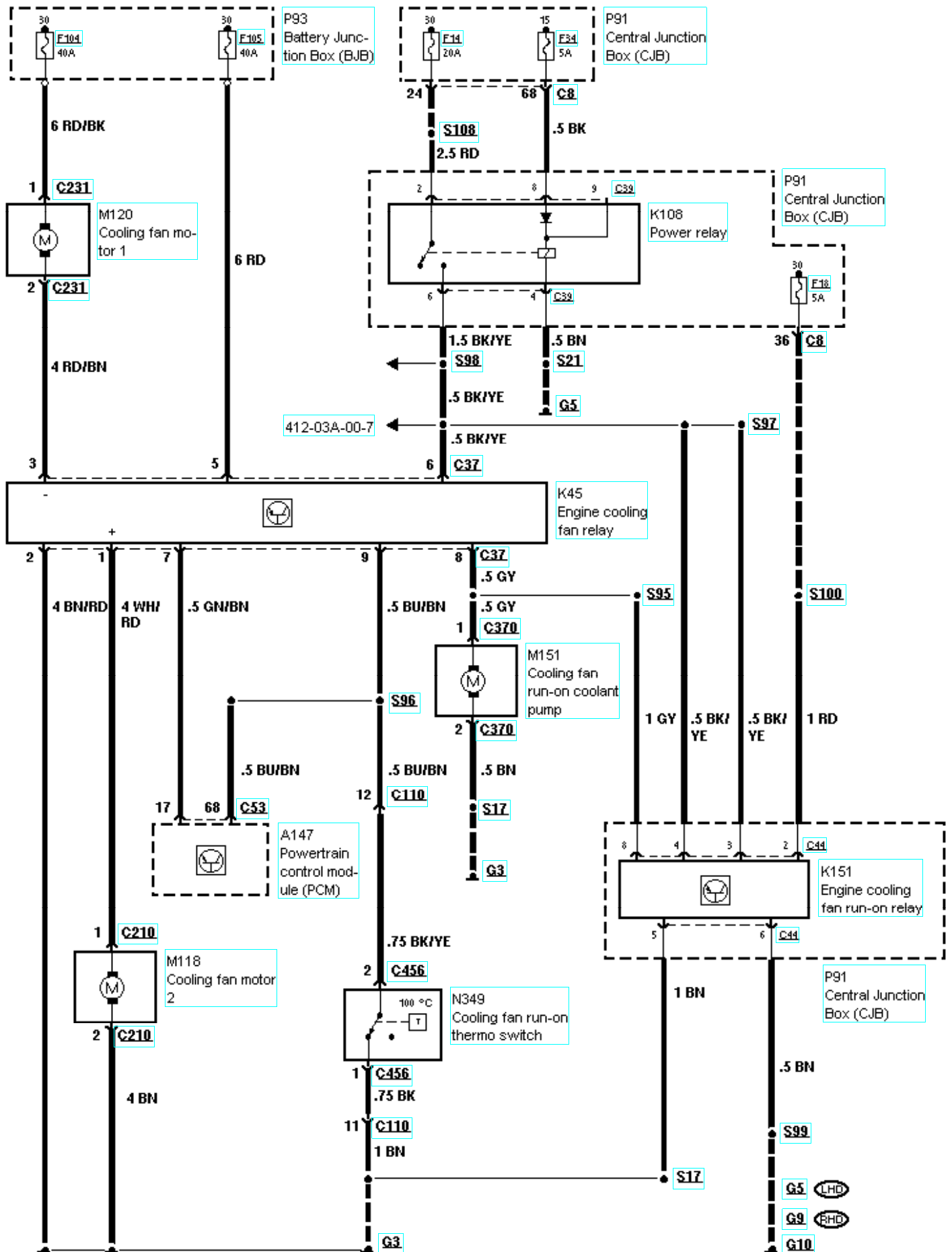

412-03A-00-006, Air Conditioning, Air conditioning without ATC module, 2,0i/2,3i DOHC, as of 05/2001

412-03A-00-007, Air Conditioning, Air conditioning without ATC module, 2,0i/2,3i DOHC

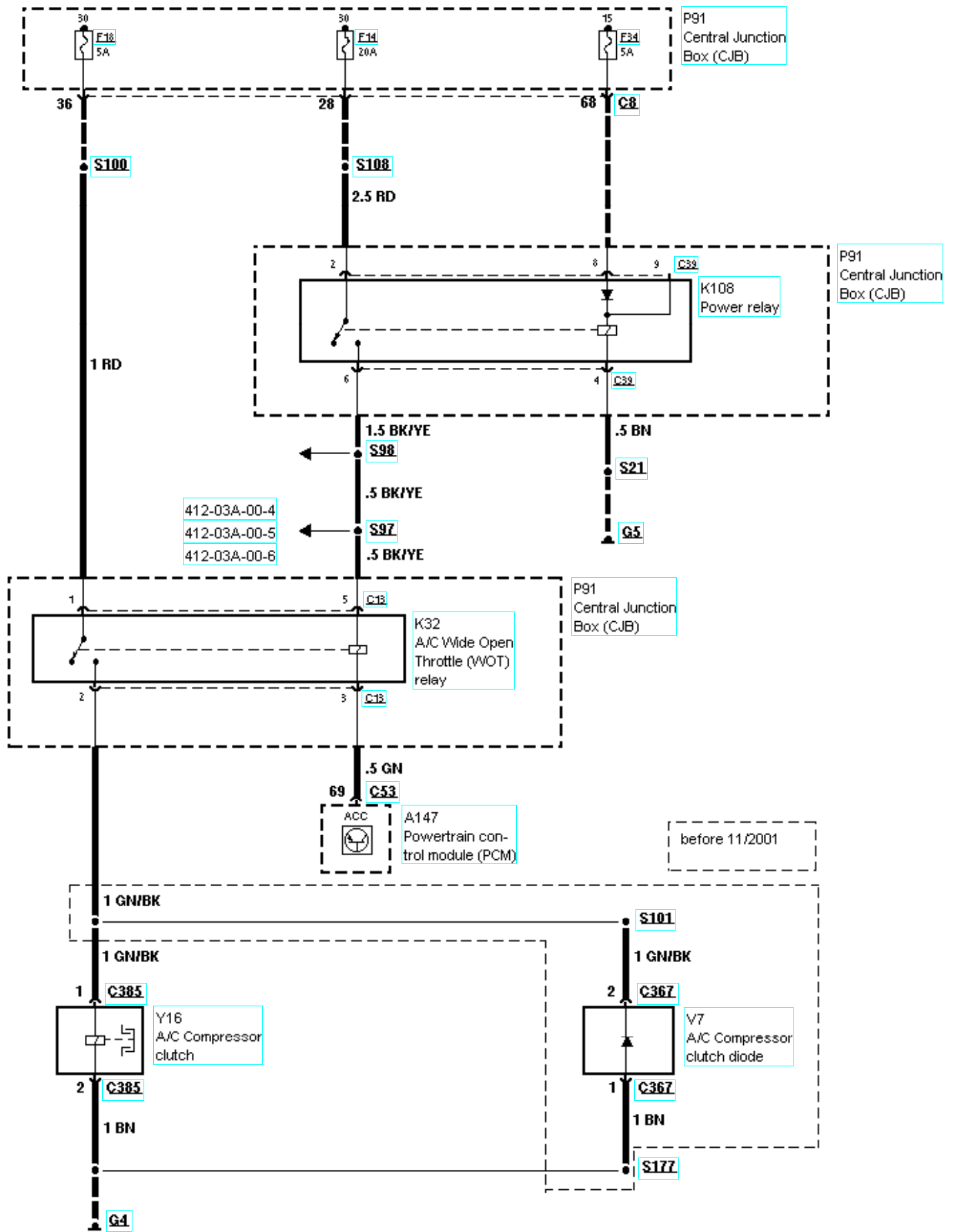

412-03A-00-008, Air Conditioning, Air conditioning without ATC module, 2,0i/2,3i DOHC

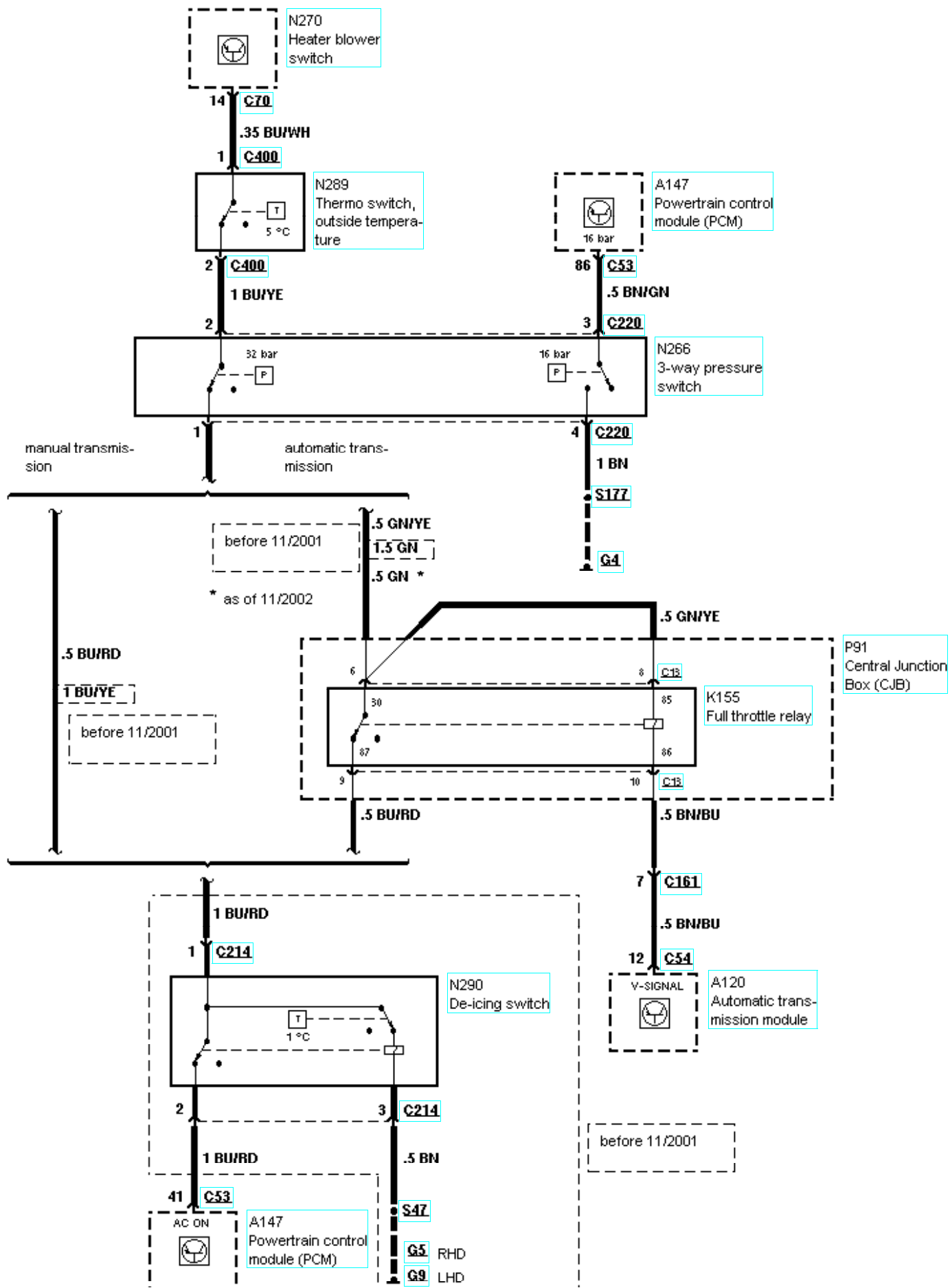

412-03A-00-009, Air Conditioning, Air conditioning without ATC module, 2,8i CD-V6 24V, before 05/2001

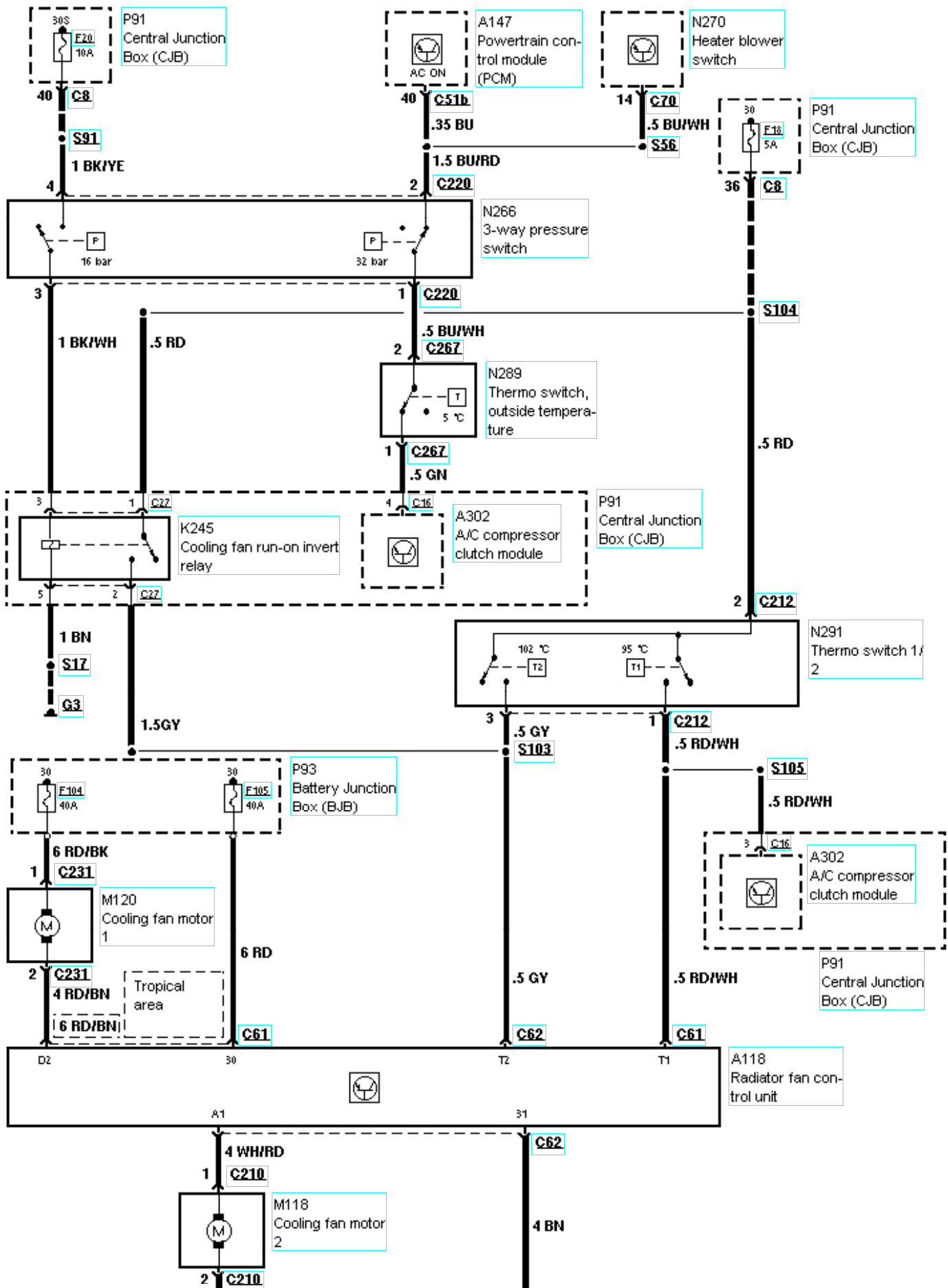

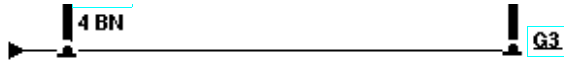

412-03A-00-010, Air Conditioning, Air conditioning without ATC module, 2,8i CD-V6 24V, from 05/2001 to 11/2001



412-03A-00-011, Air Conditioning, Air conditioning without ATC module, 2,8i CD-V6 24V, from 11/2001 to 11/2002

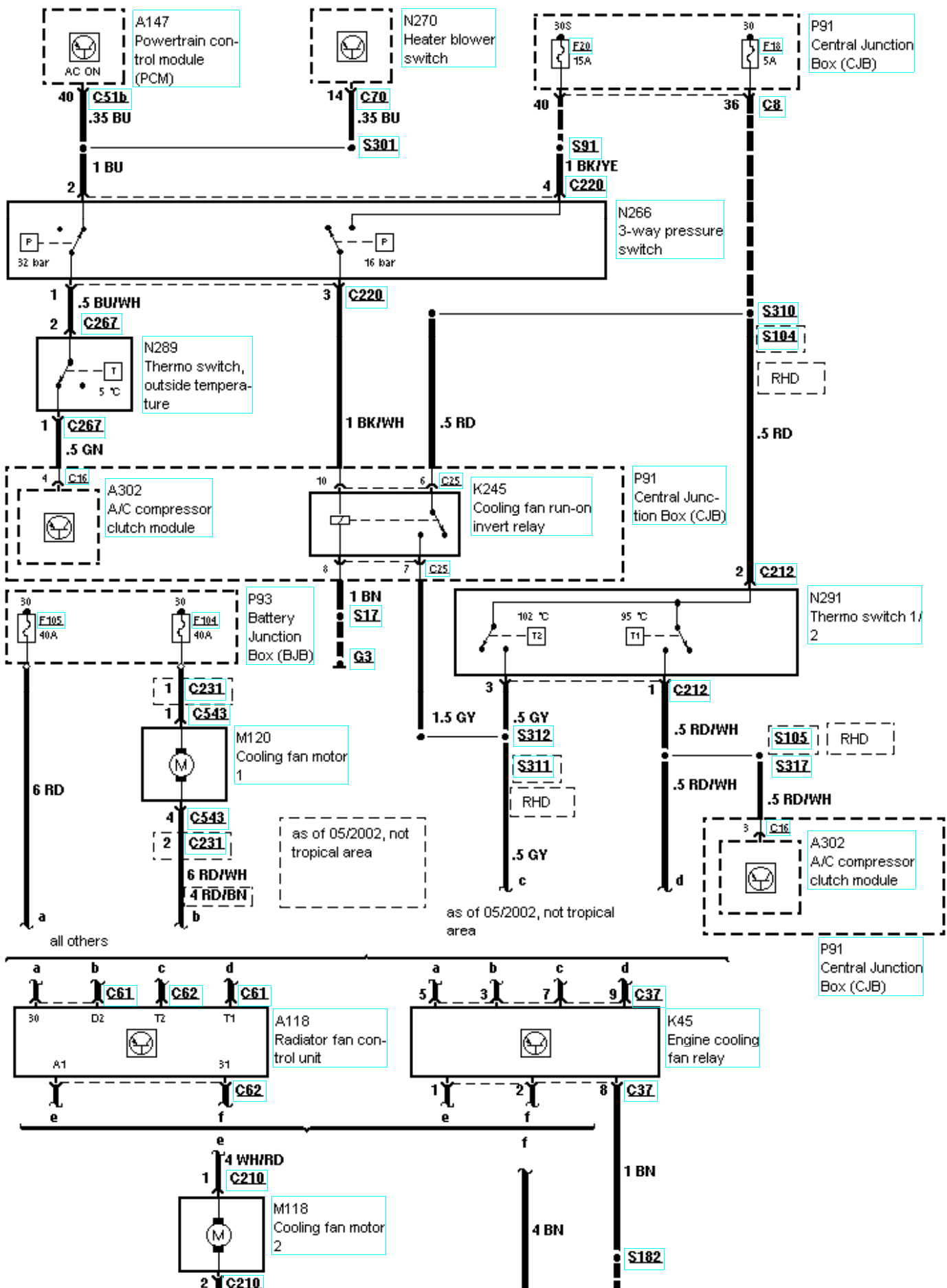

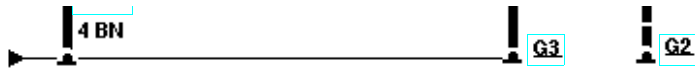

412-03A-00-012, Air Conditioning, Air conditioning without ATC module, 2,8i CD-V6 24V, as of 11/2002

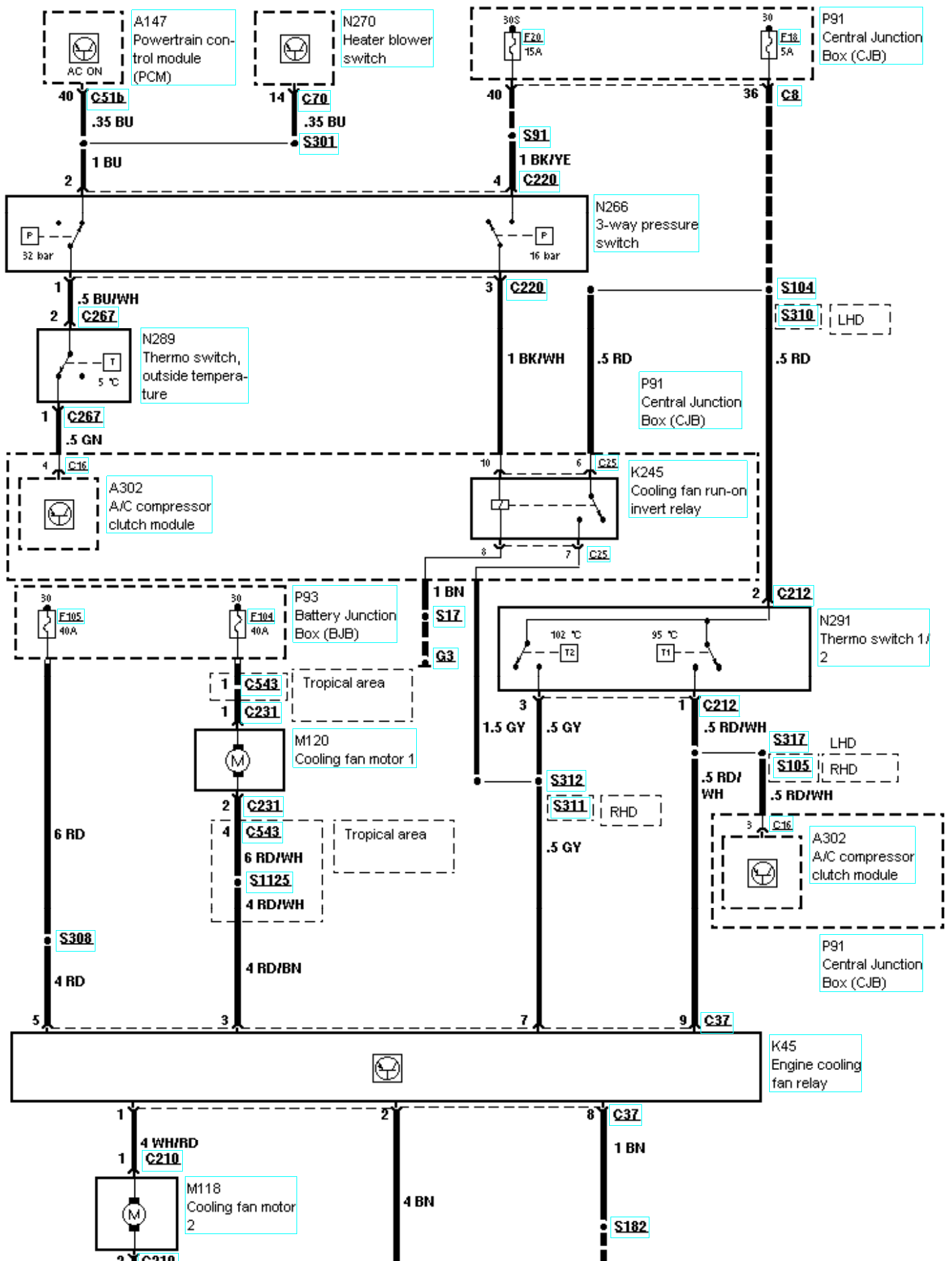

4 BN

G3

G2

412-03A-00-013, Air Conditioning, Air conditioning without ATC module, 1,9 TDI unit injector engine, before
05/2001

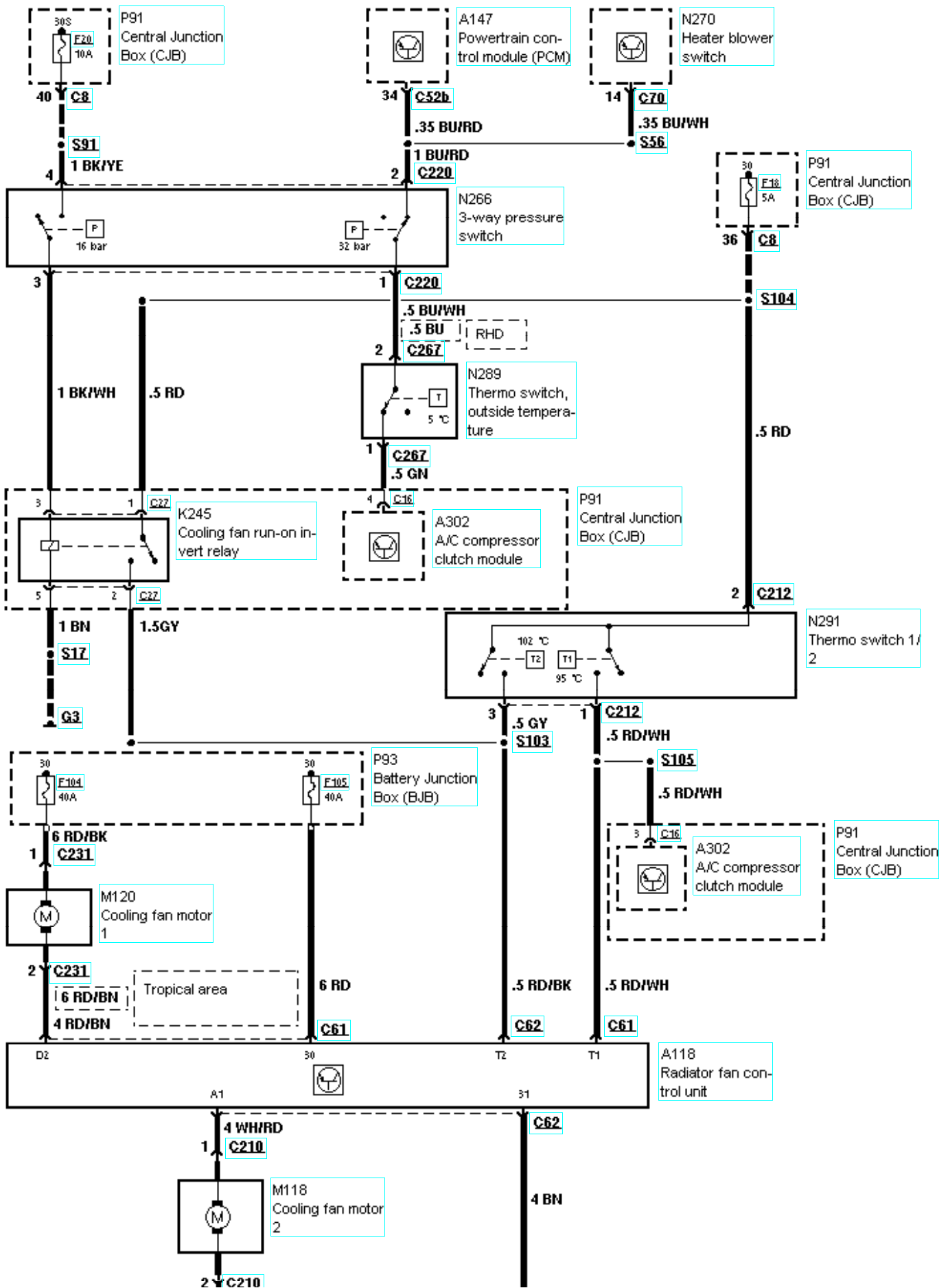



412-03A-00-014, Air Conditioning, Air conditioning without ATC module, 1,9 TDI unit injector engine, from 05/2001 to 11/2001

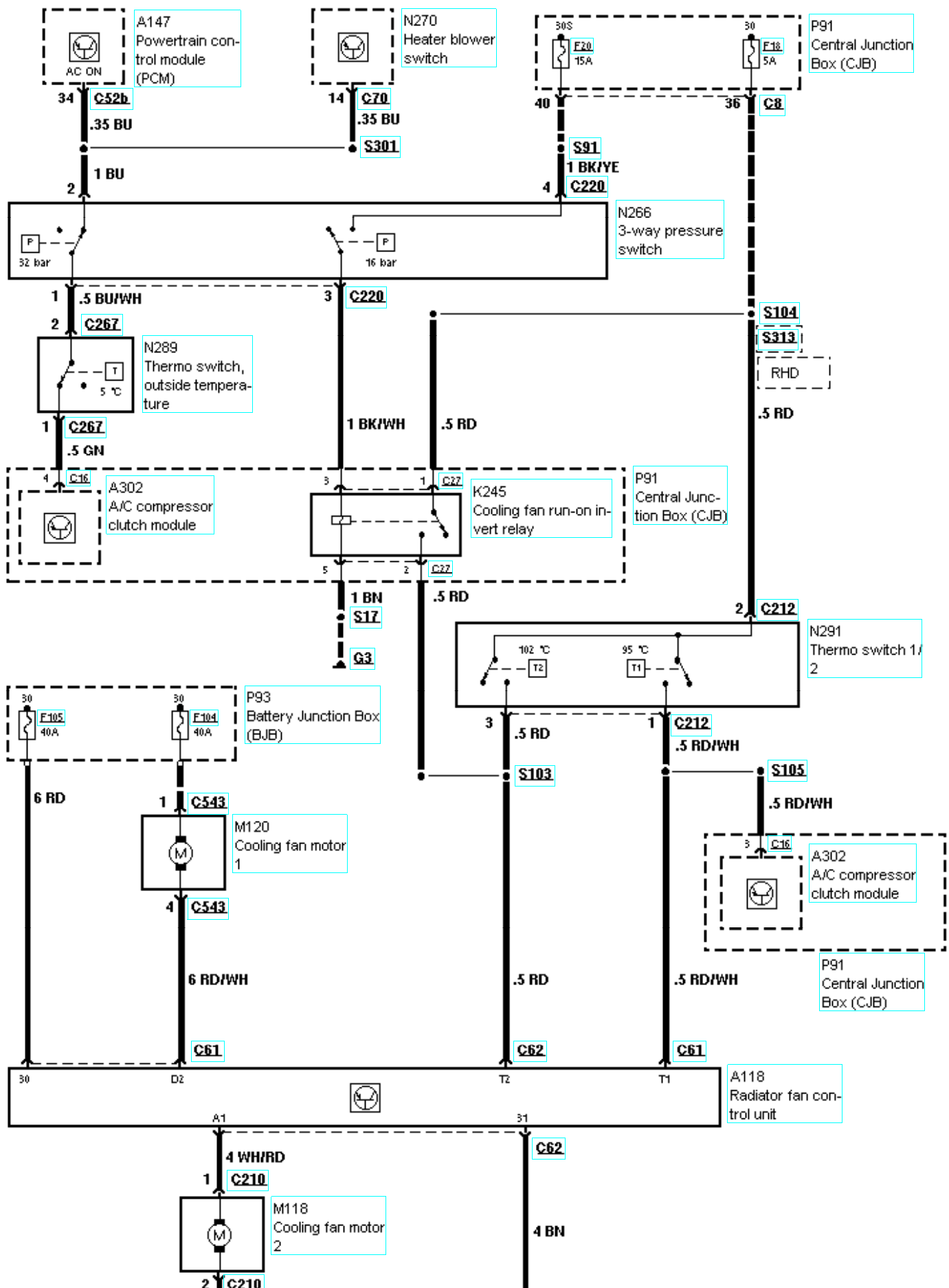

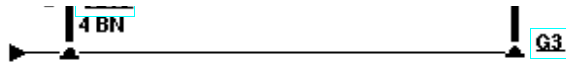

412-03A-00-015, Air Conditioning, Air conditioning without ATC module, 1,9 TDI unit injector engine, except 96kW engine, as of 11/2001

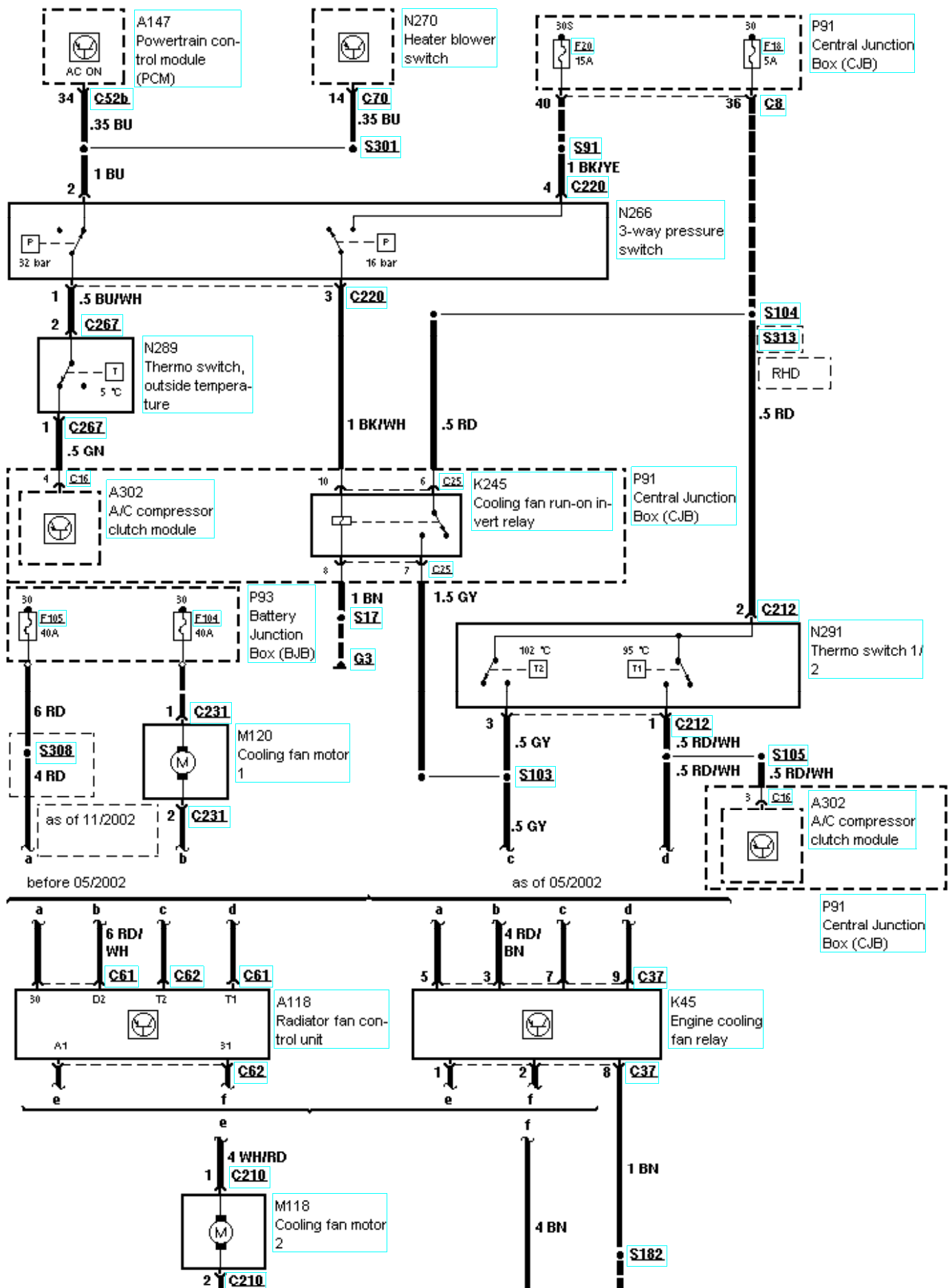

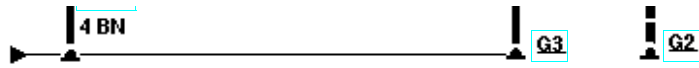

412-03A-00-016, Air Conditioning, Air conditioning without ATC module, 2,8i CD-V6 24V

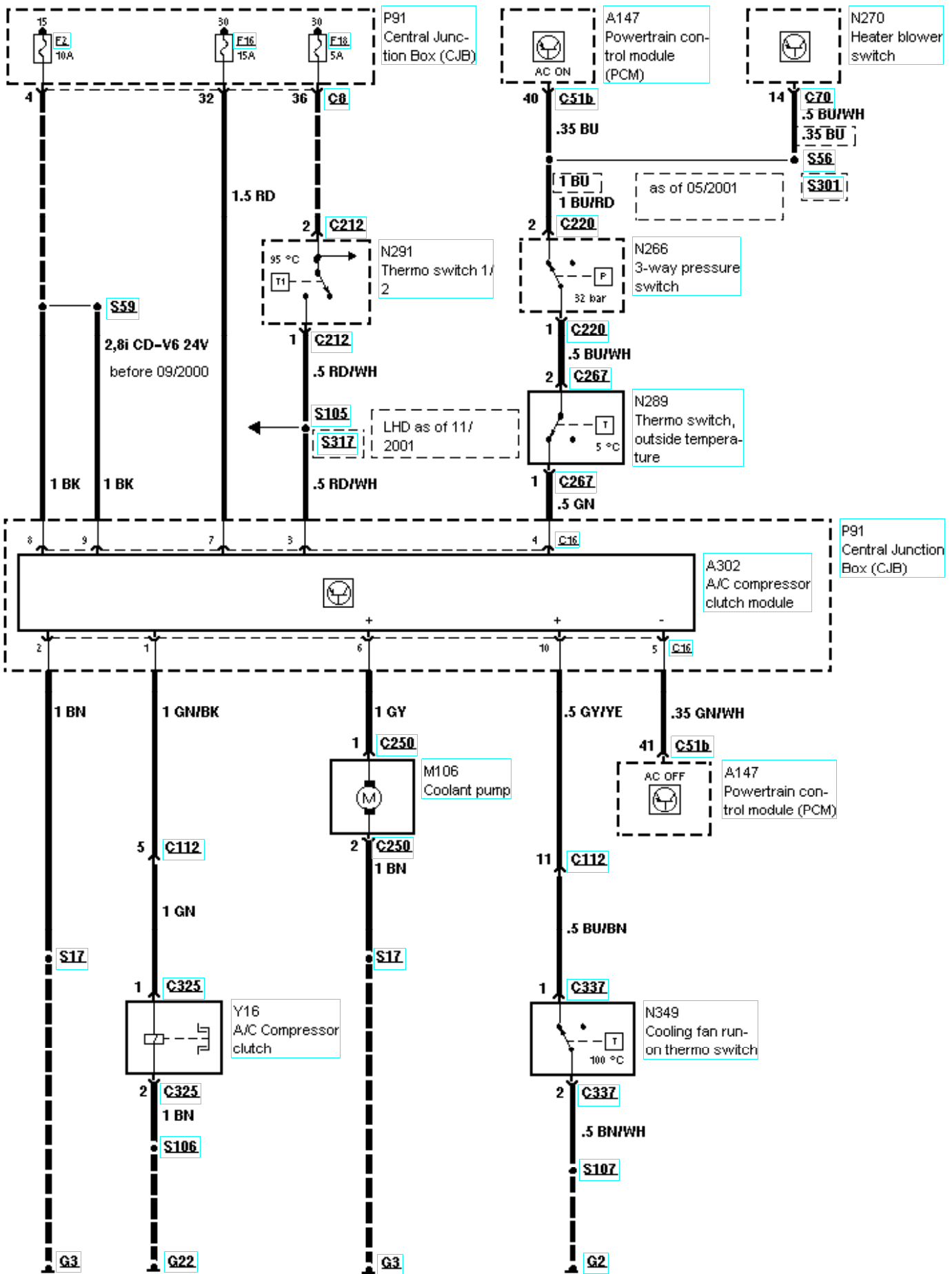

412-03A-00-017, Air Conditioning, Air conditioning without ATC module, 1,9 TDI unit injector engine, except 96kW engine

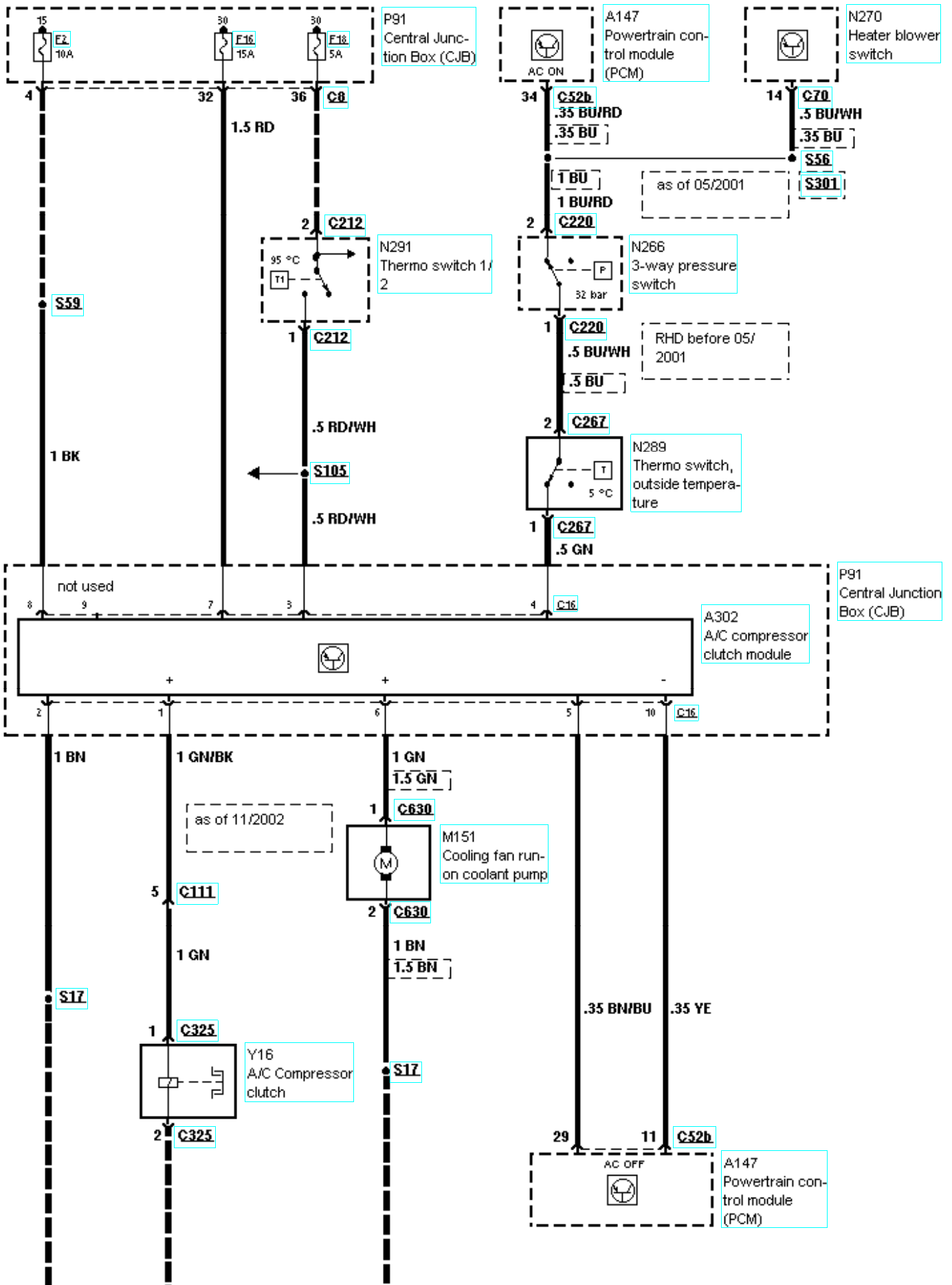



412-03A-00-018, Air Conditioning, Air conditioning without ATC module, 1,9 TDI unit injector engine, 96kW engine

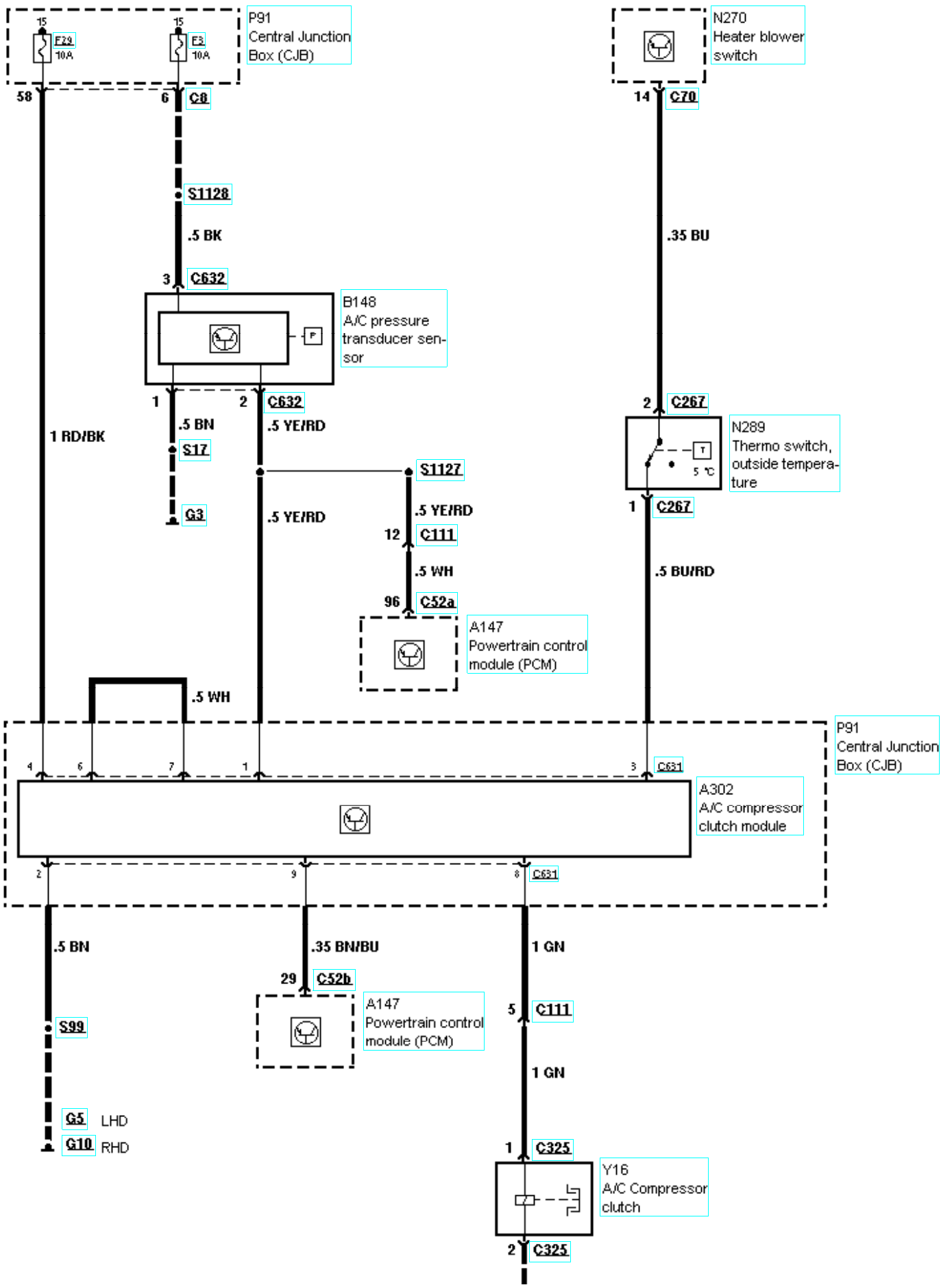



412-03A-00-019, Air Conditioning, Air conditioning without ATC module, 1,9 TDI unit injector engine, 96kW engine

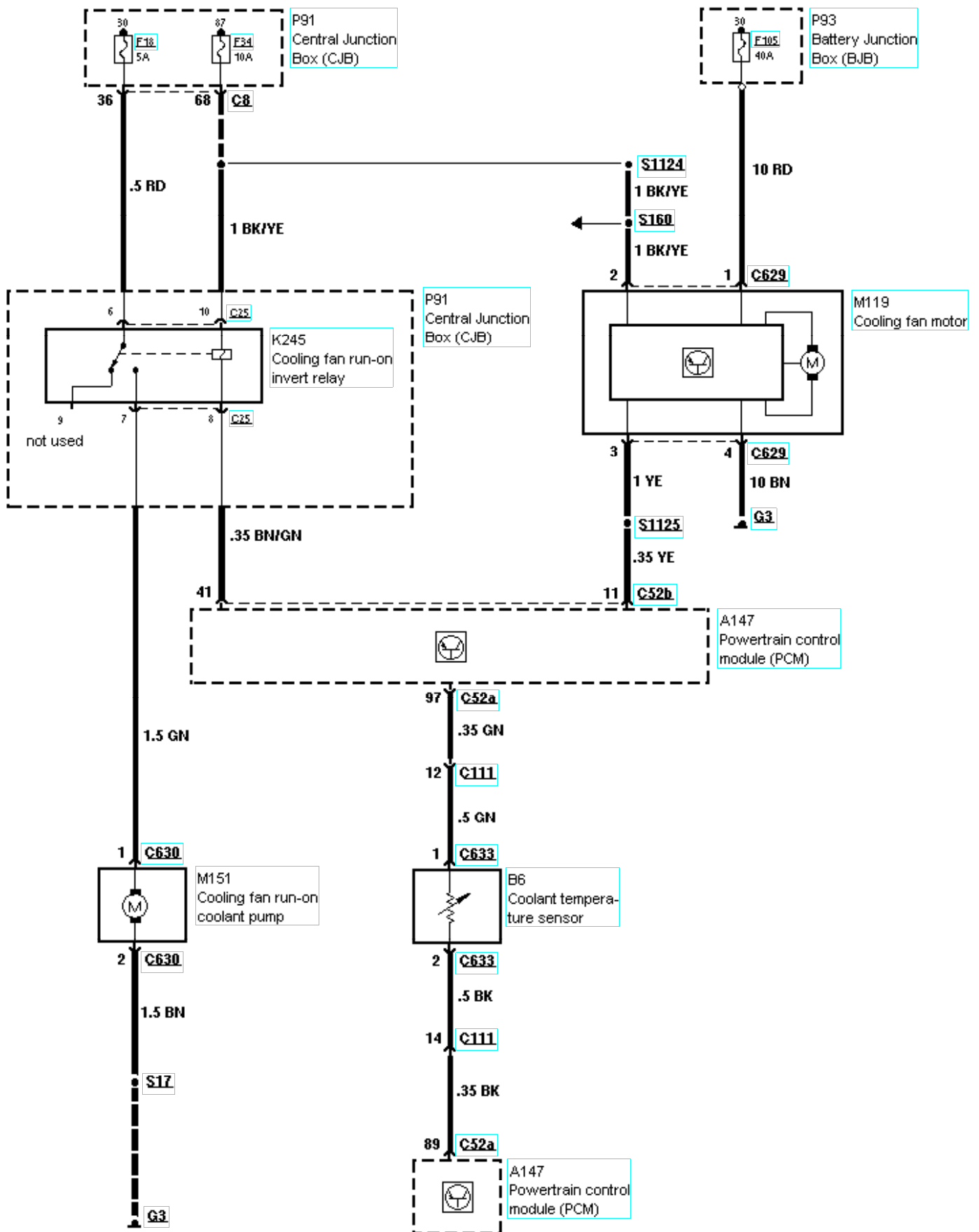

P91
Central Junction
Box (CJB)

* LHD as of 11/2001

** RHD as of 11/2001

*** as of 11/2002

before 05/2001 1,
9 TDI unit injector
engine 2,8i CD-V6
24V

as of 05/2001

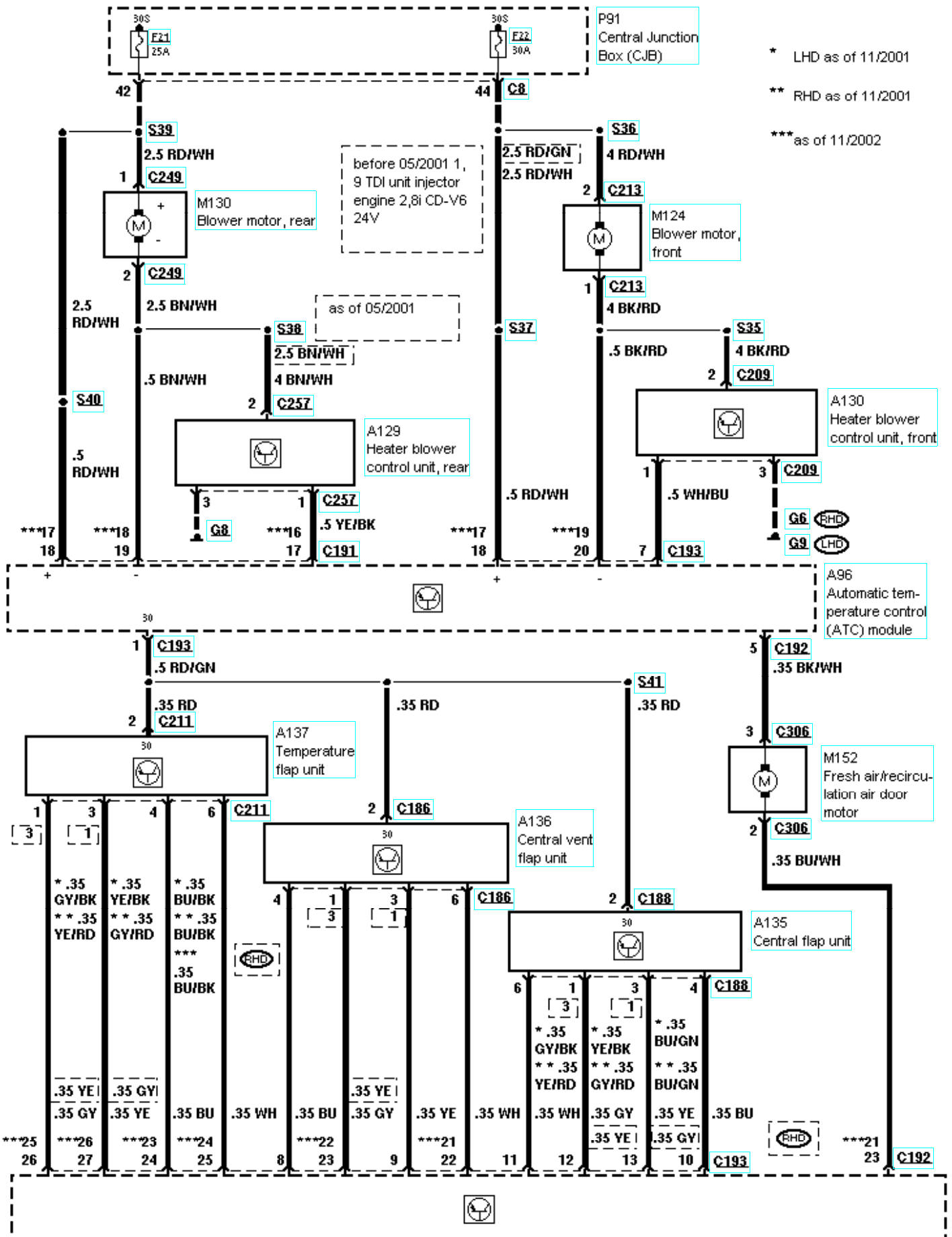

412-03A-00-022, Air Conditioning, Air conditioning with ATC module

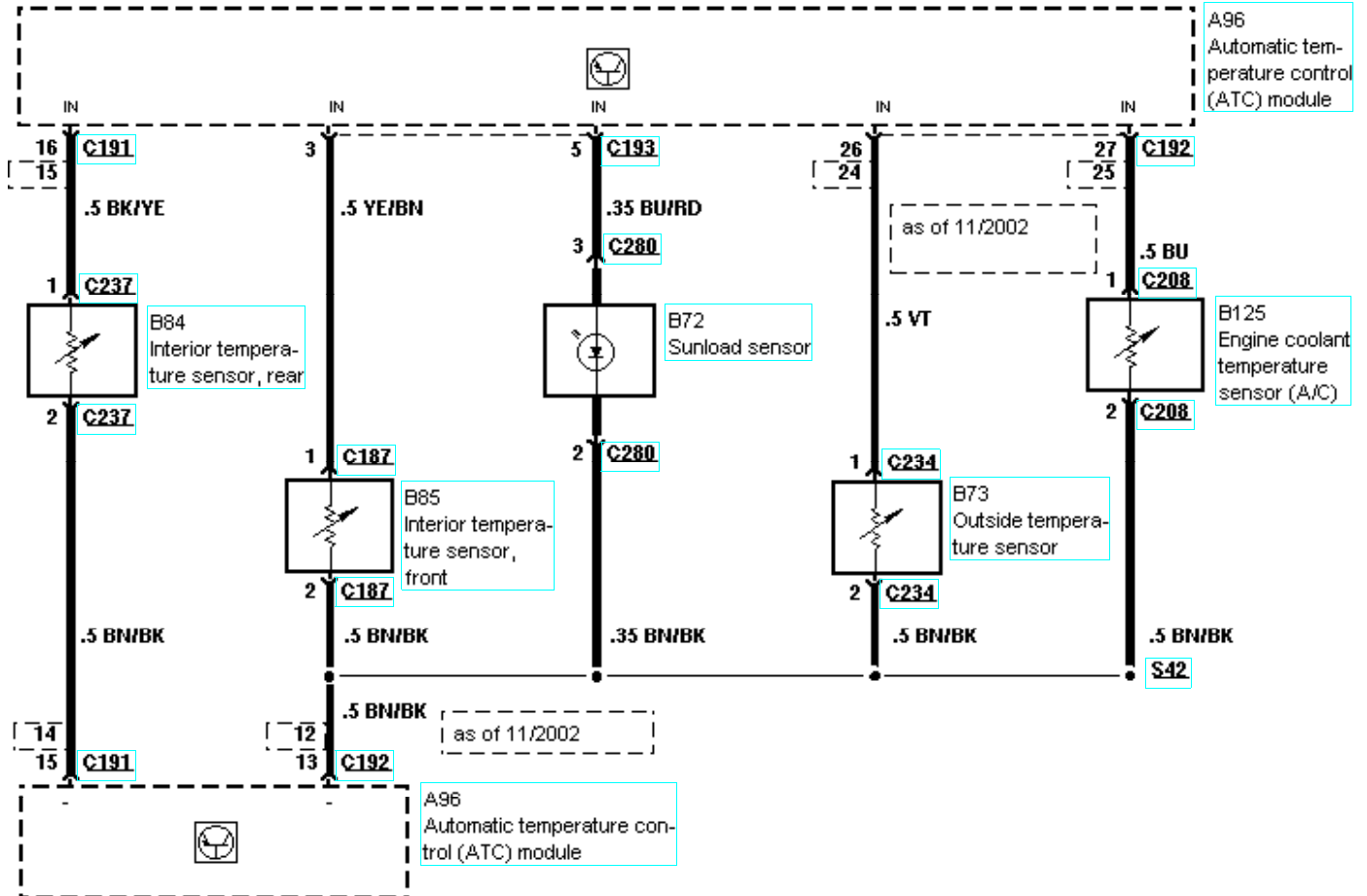

412-03A-00-023, Air Conditioning, Air conditioning with ATC module, front and rear

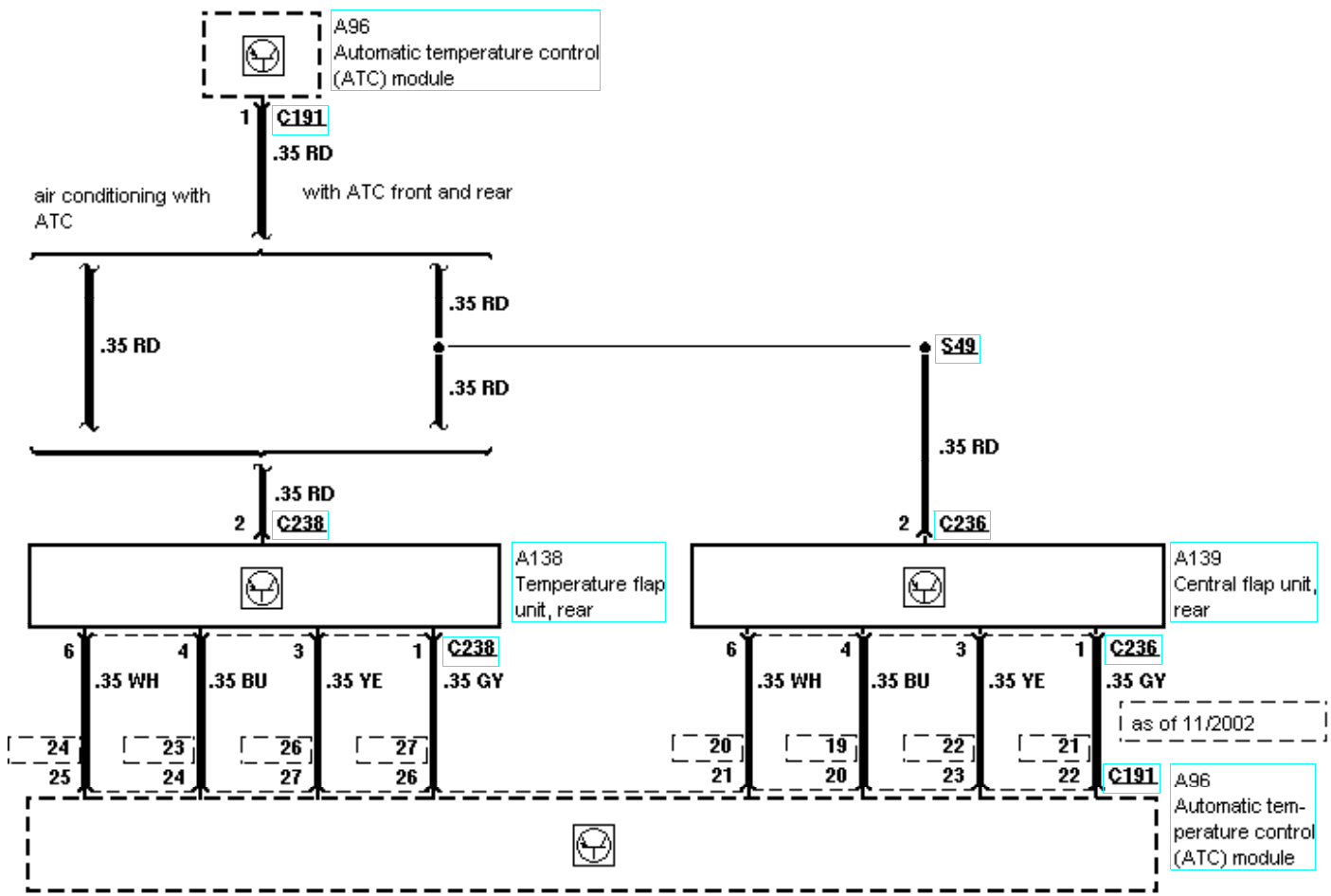

412-03A-00-024, Air Conditioning, Air conditioning with ATC module, 2,0i/2,3i DOHC, before 09/2000

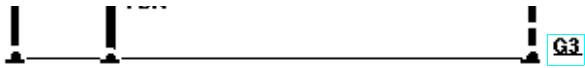

412-03A-00-025, Air Conditioning, Air conditioning with ATC module, 2,0i/2,3i DOHC, from 09/2000 to 05/2001

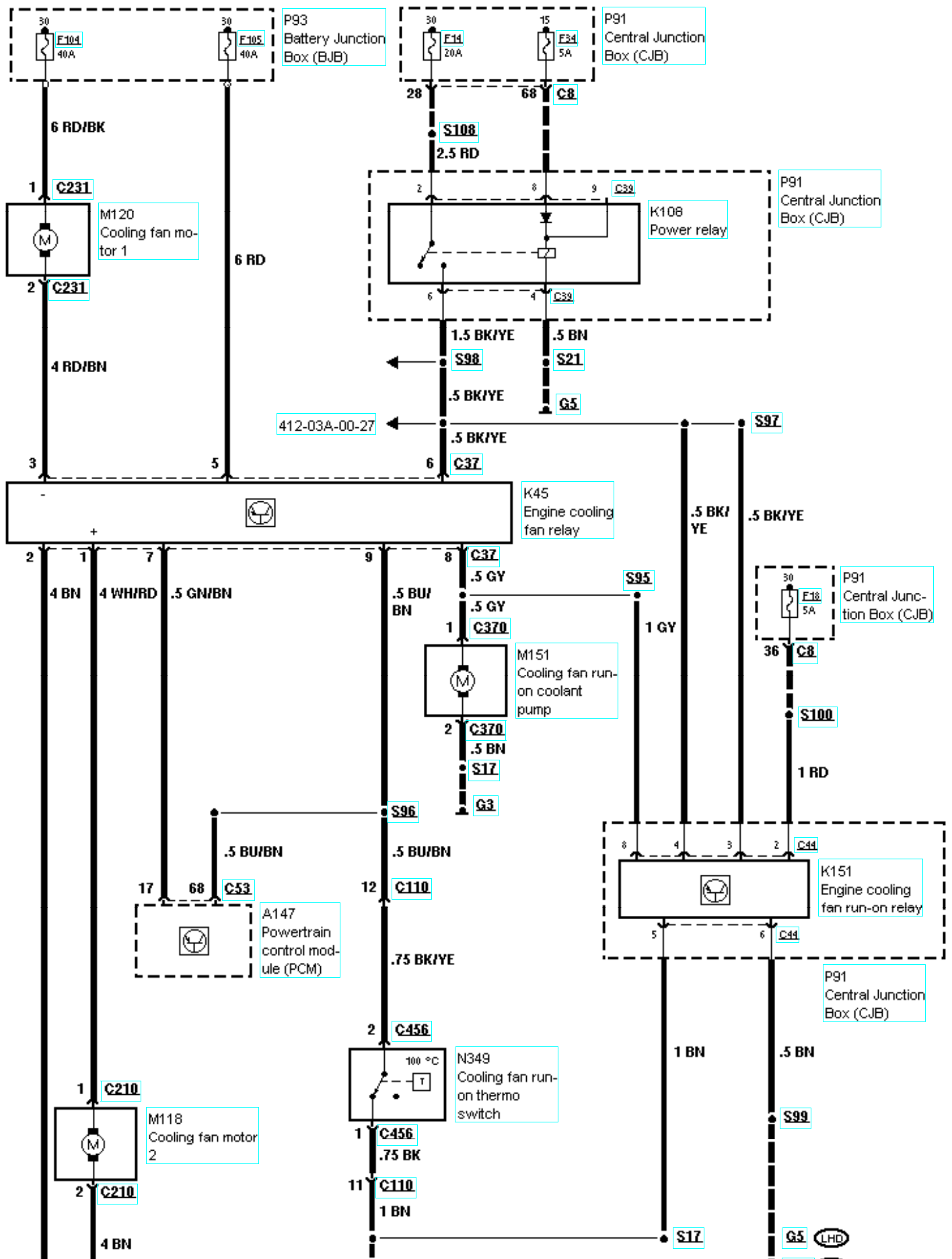

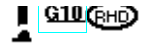

412-03A-00-026, Air Conditioning, Air conditioning with ATC module, 2,0i/2,3i DOHC, as of 05/2001

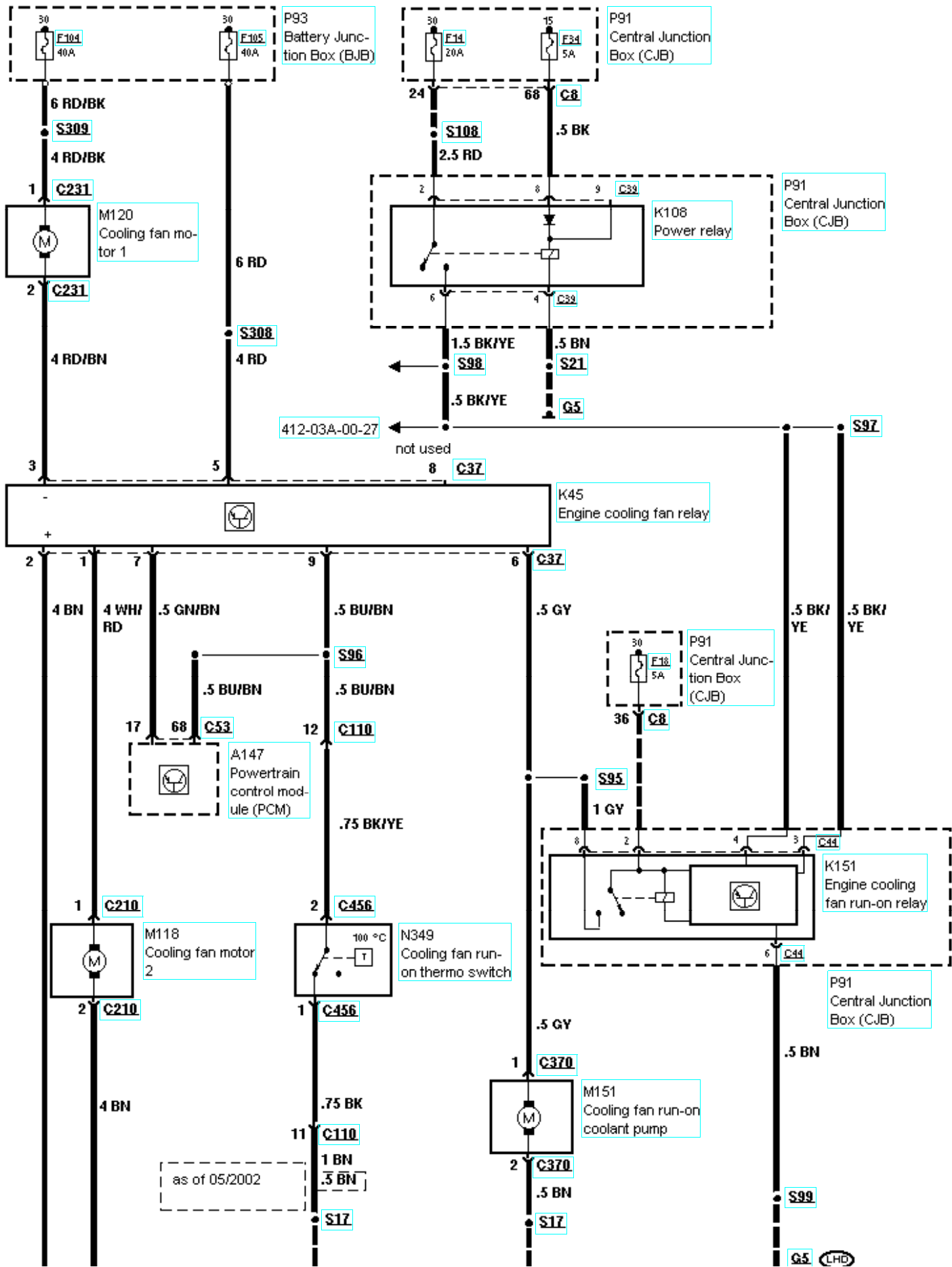

as of 05/2002

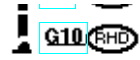
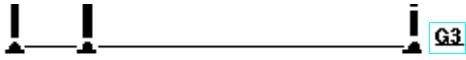

412-03A-00-027, Air Conditioning, Air conditioning with ATC module, 2,0i/2,3i DOHC

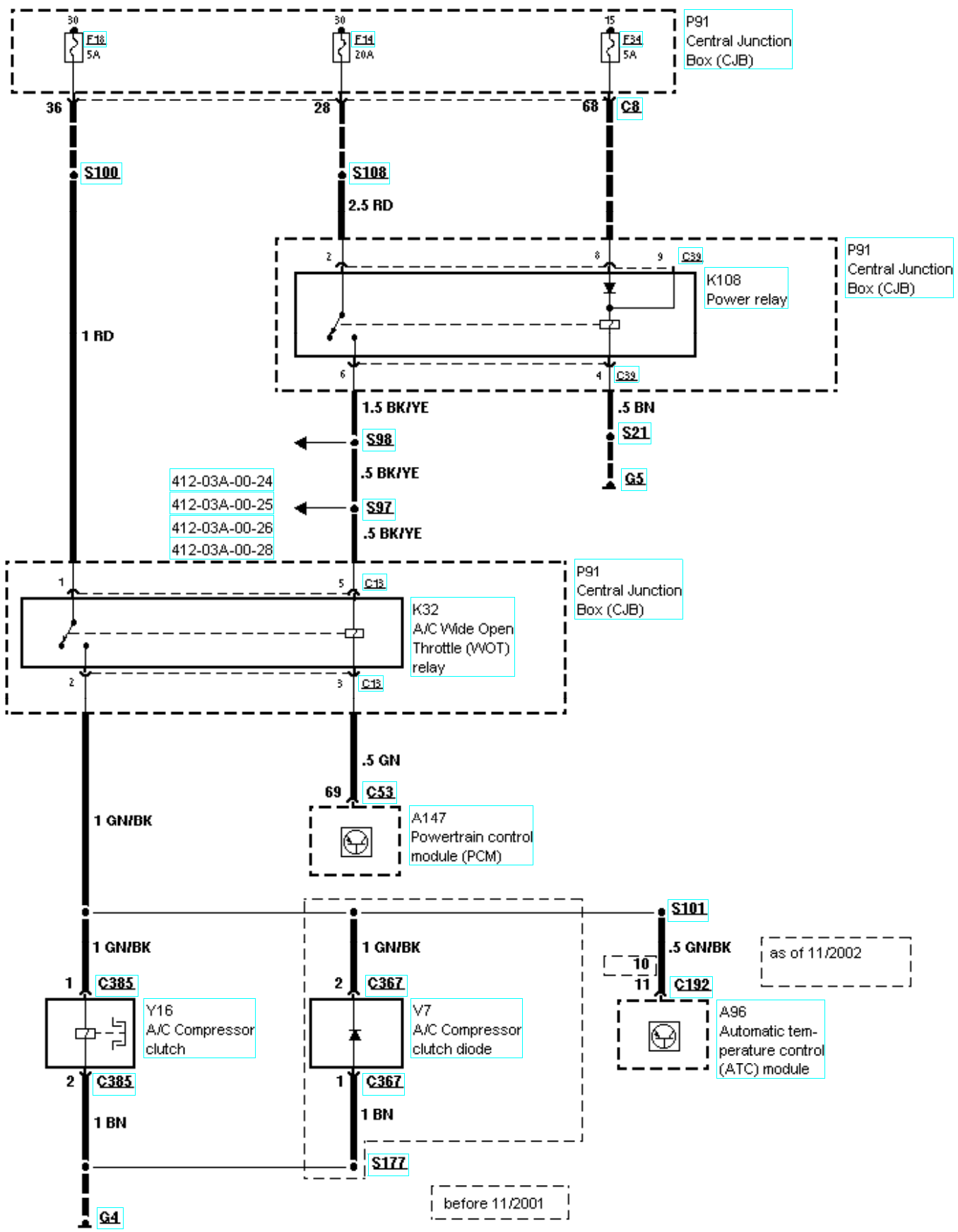

412-03A-00-028, Air Conditioning, Air conditioning with ATC module, 2,0i/2,3i DOHC

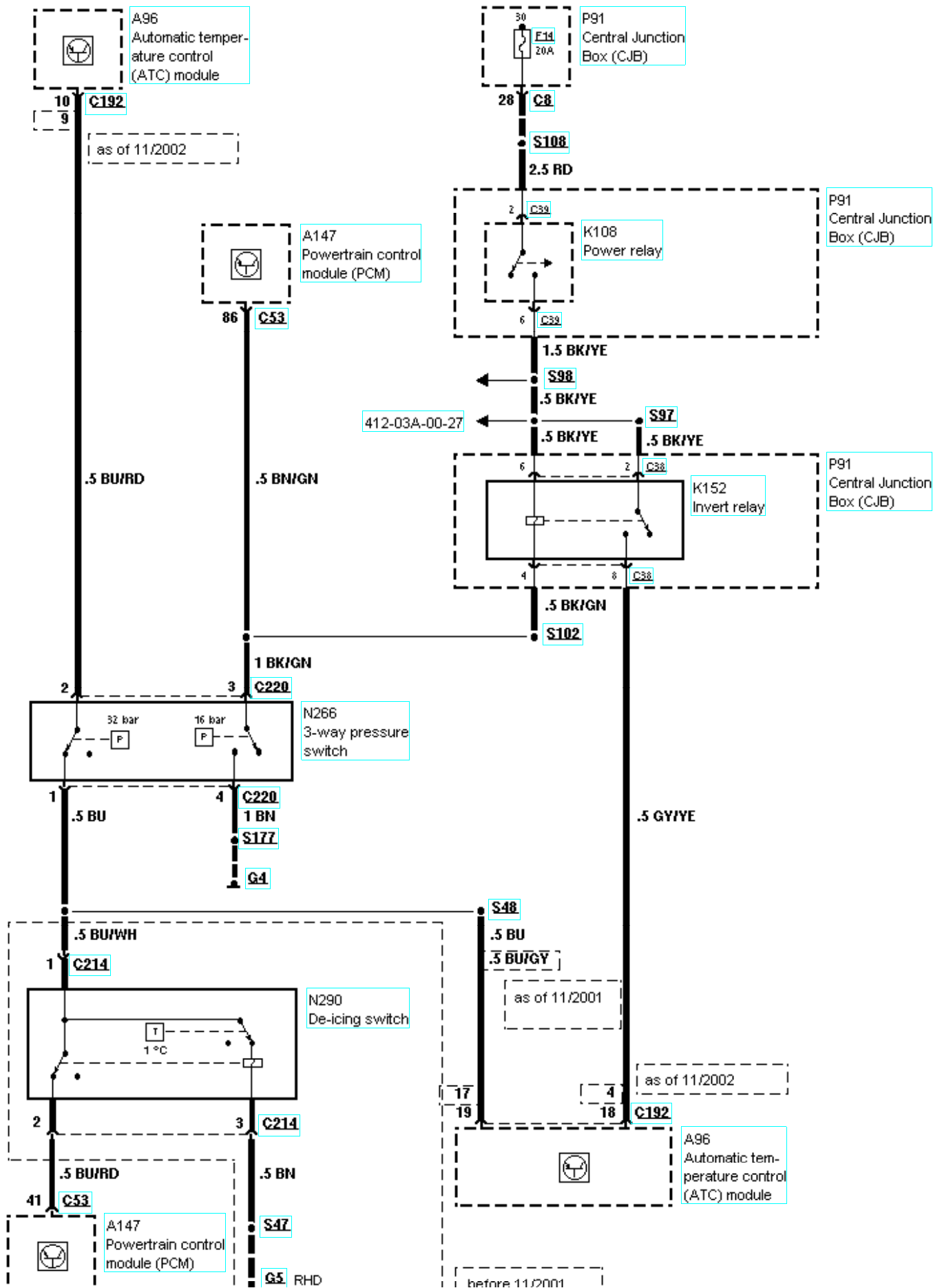

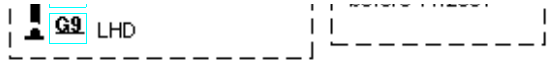

412-03A-00-029, Air Conditioning, Air conditioning with ATC module, 2,8i CD-V6 24V, before 05/2001

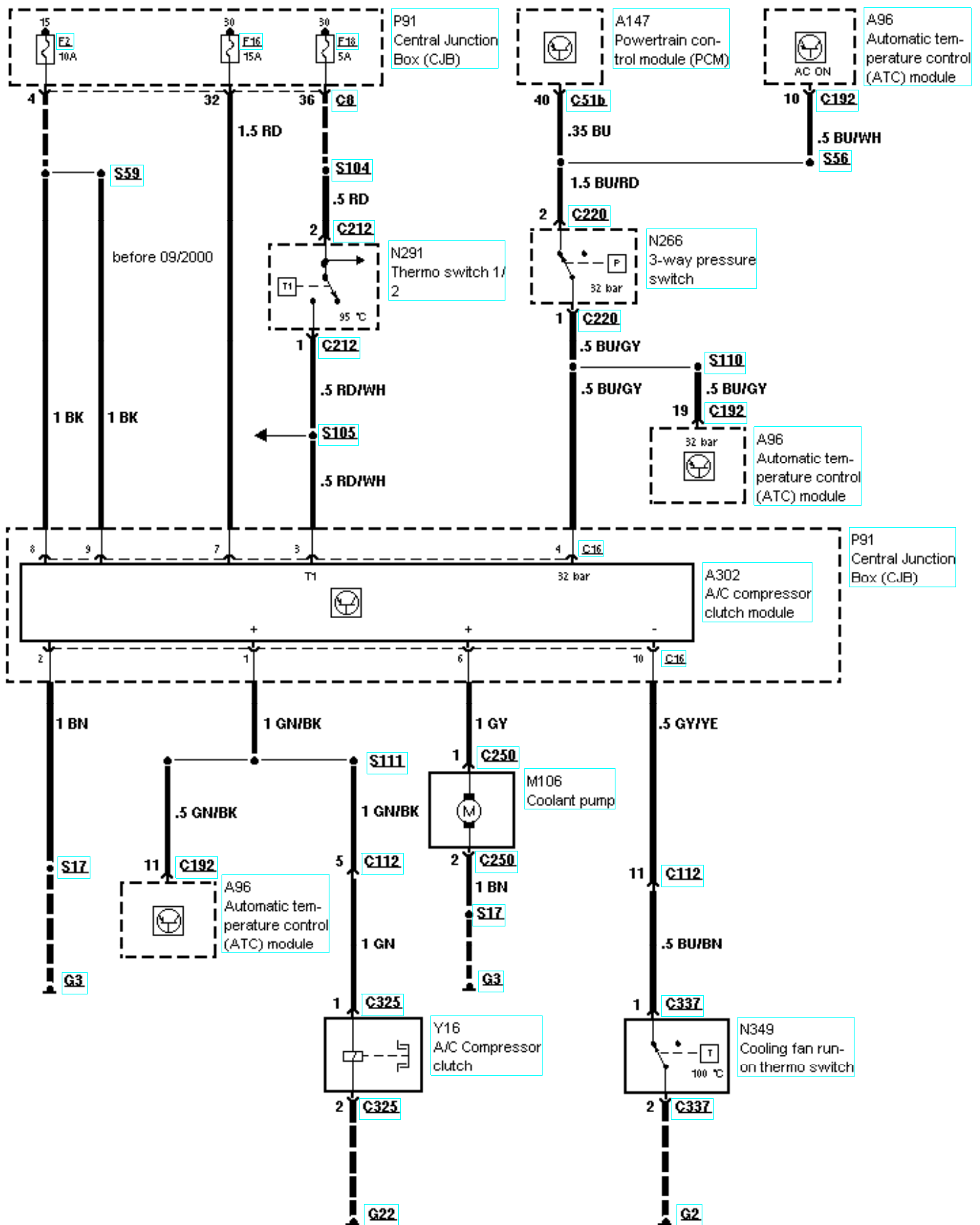

412-03A-00-030, Air Conditioning, Air conditioning with ATC module, 2,8i CD-V6 24V, as of 05/2001

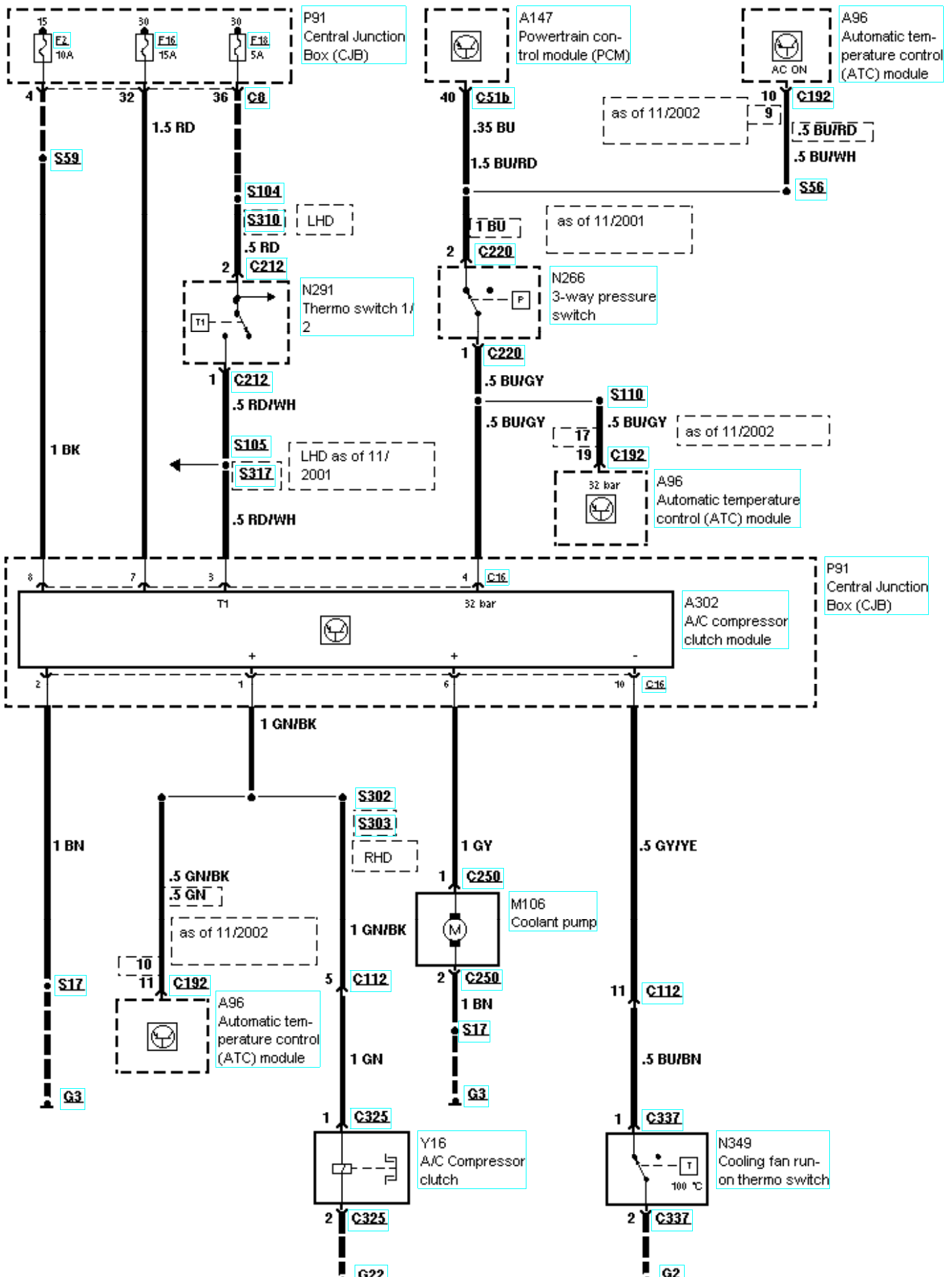



**412-03A-00-031, Air Conditioning, Air conditioning with ATC module, 1,9 TDI unit injector engine, before
05/2001**

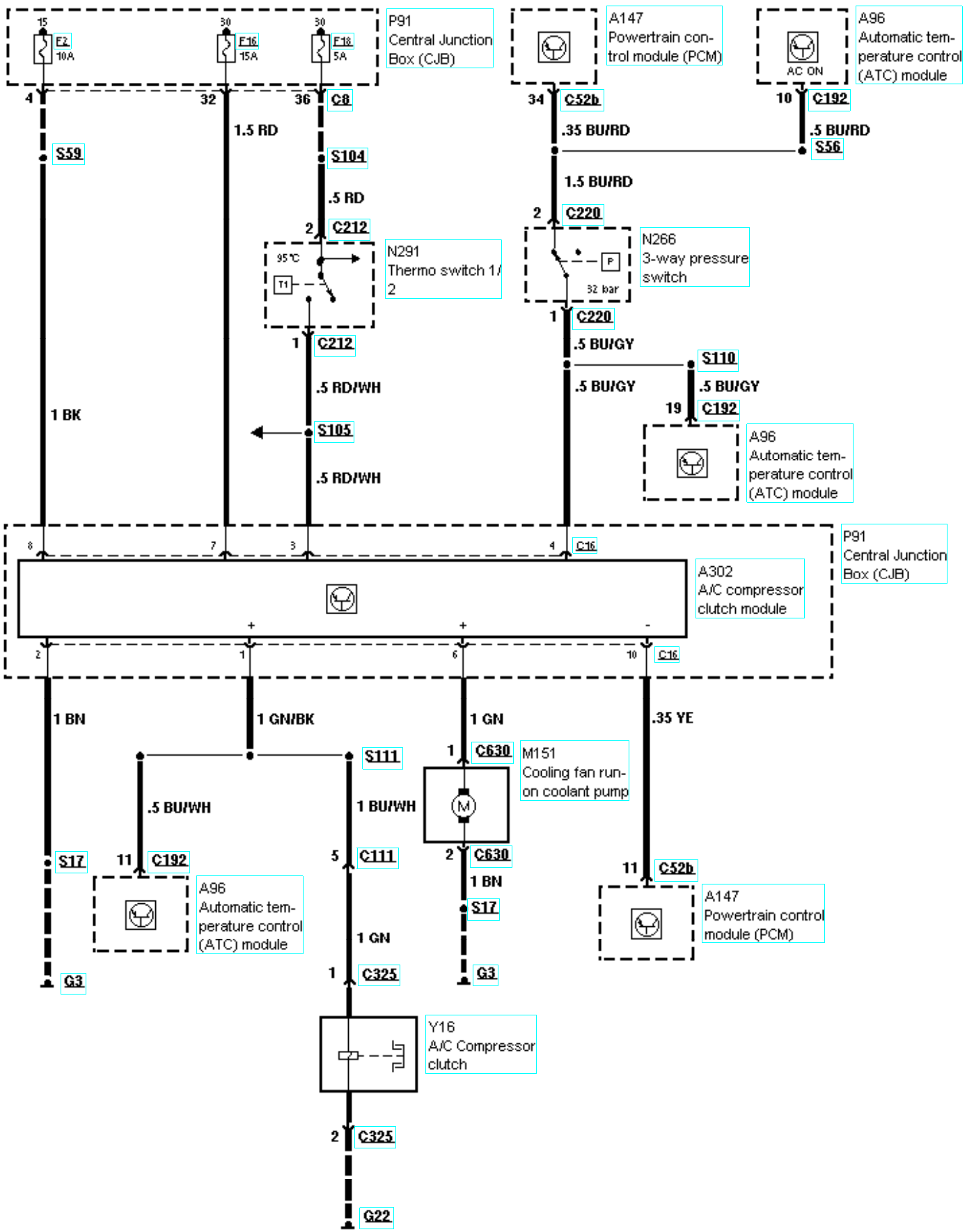

412-03A-00-032, Air Conditioning, Air conditioning with ATC module, 1,9 TDI unit injector engine, except 96kW engine, as of 05/2001

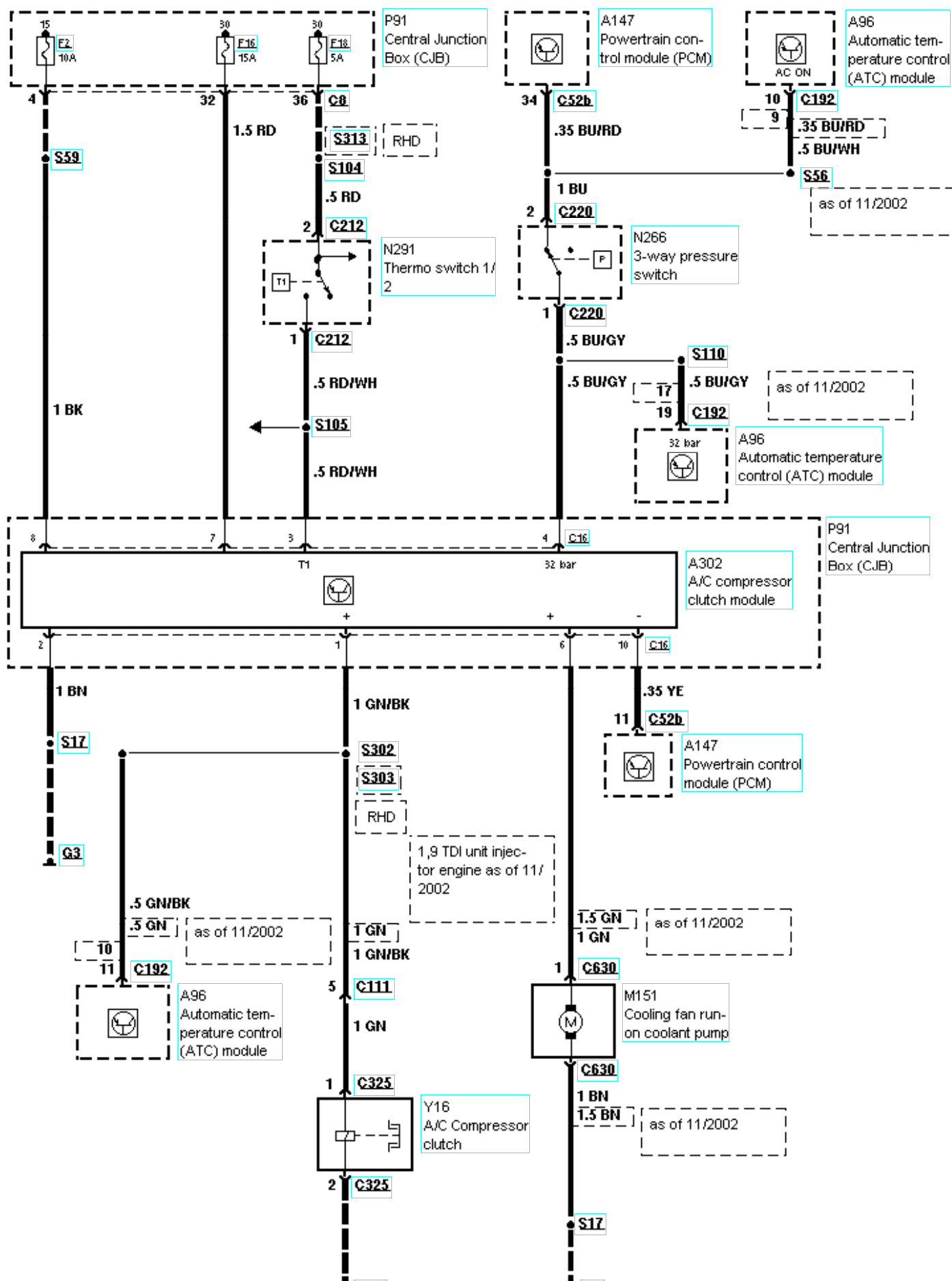

412-03A-00-033, Air Conditioning, Air conditioning with ATC module, 2,8i CD-V6 24V, from 05/2001 to 11/2001

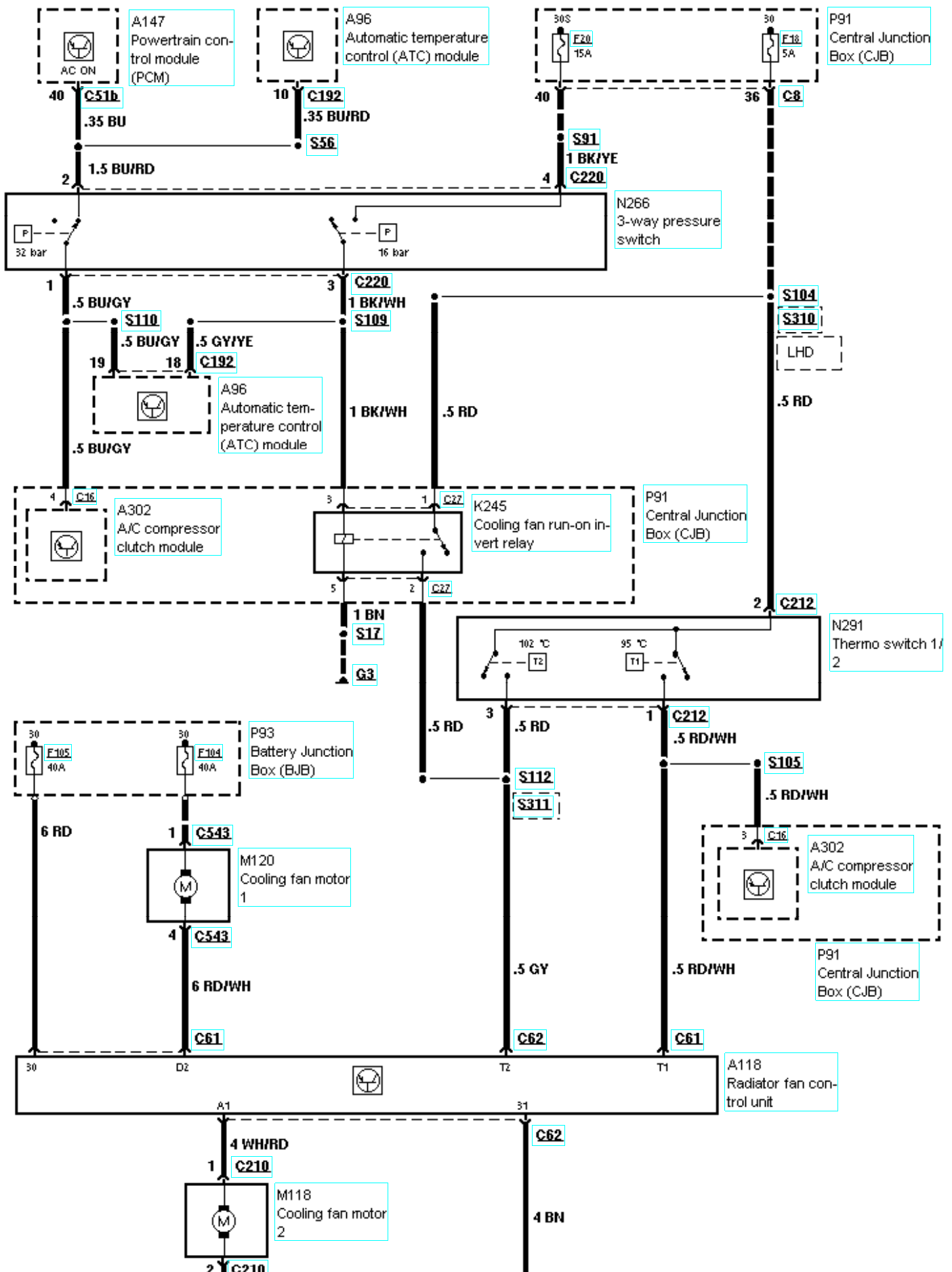



412-03A-00-034, Air Conditioning, Air conditioning with ATC module, 2,8i CD-V6 24V, from 11/2001 to 11/2002

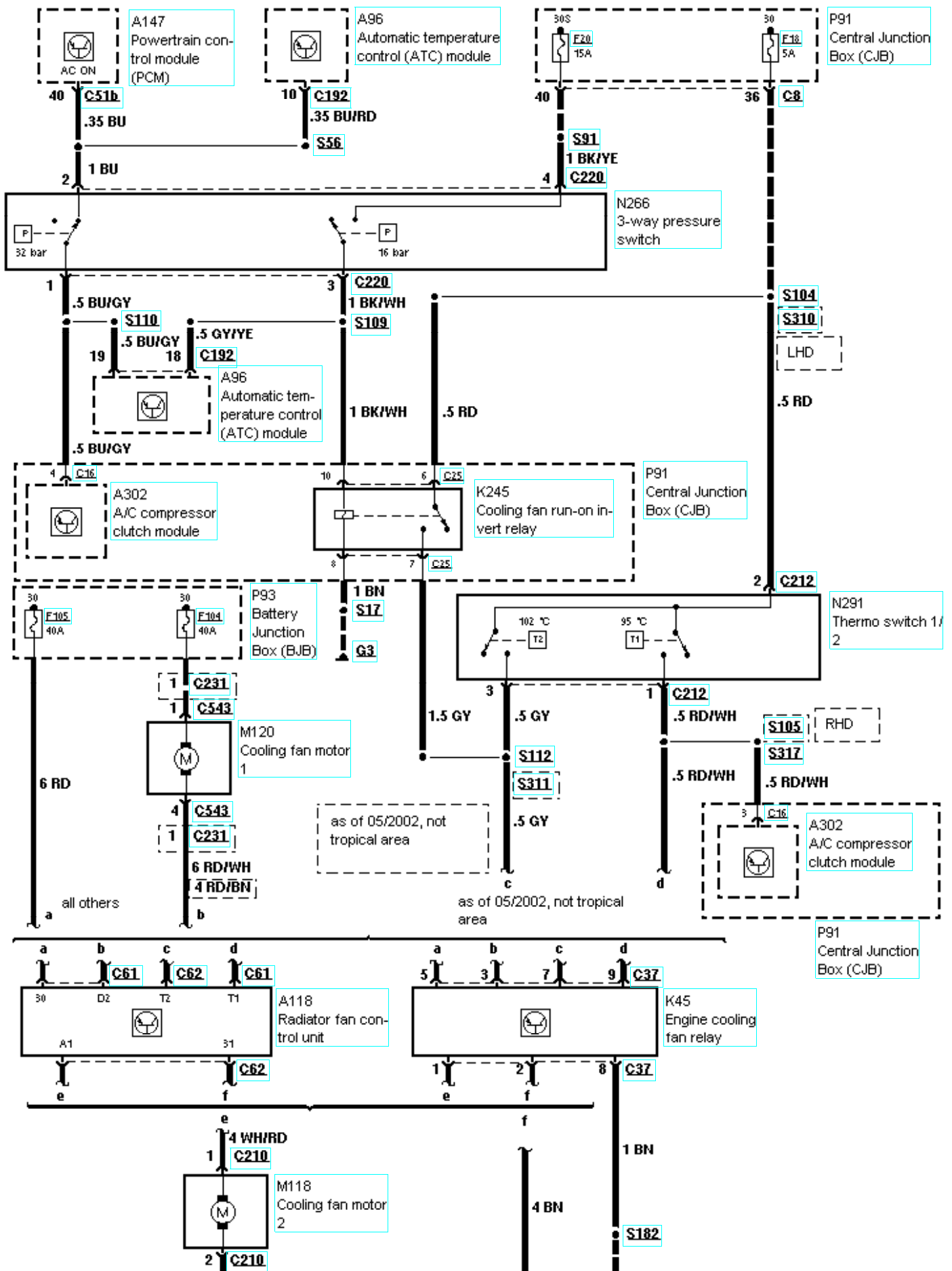

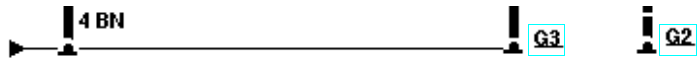

412-03A-00-035, Air Conditioning, Air conditioning with ATC module, 2,8i CD-V6 24V, as of 11/2002

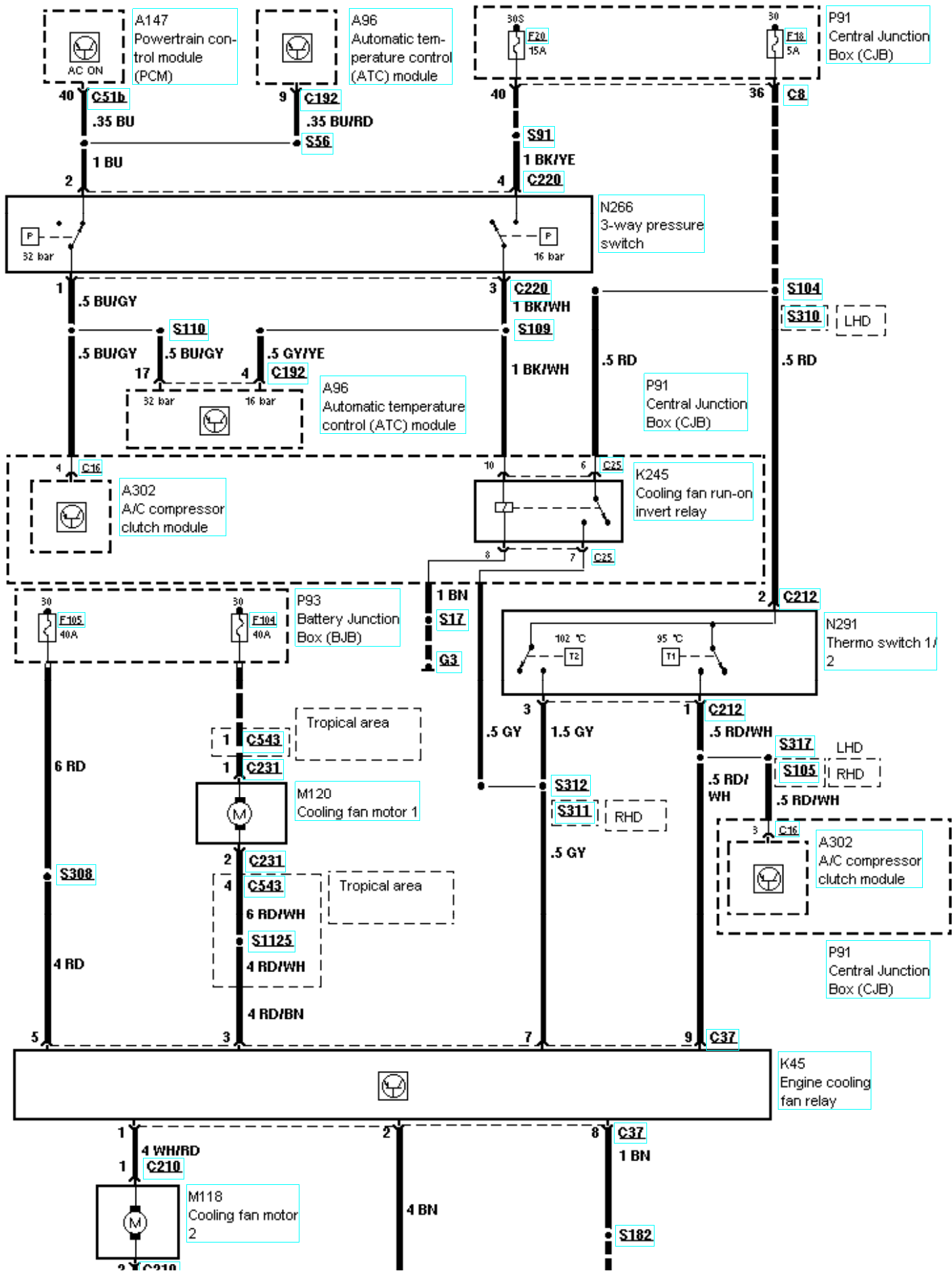

4 BN

G3

G2

412-03A-00-036, Air Conditioning, Air conditioning with ATC module, 1,9 TDI unit injector engine, before
05/2001

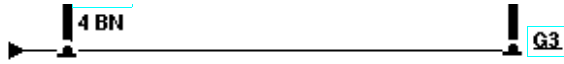

412-03A-00-037, Air Conditioning, Air conditioning with ATC module, 1,9 TDI unit injector engine, from 05/2001 to 11/2001

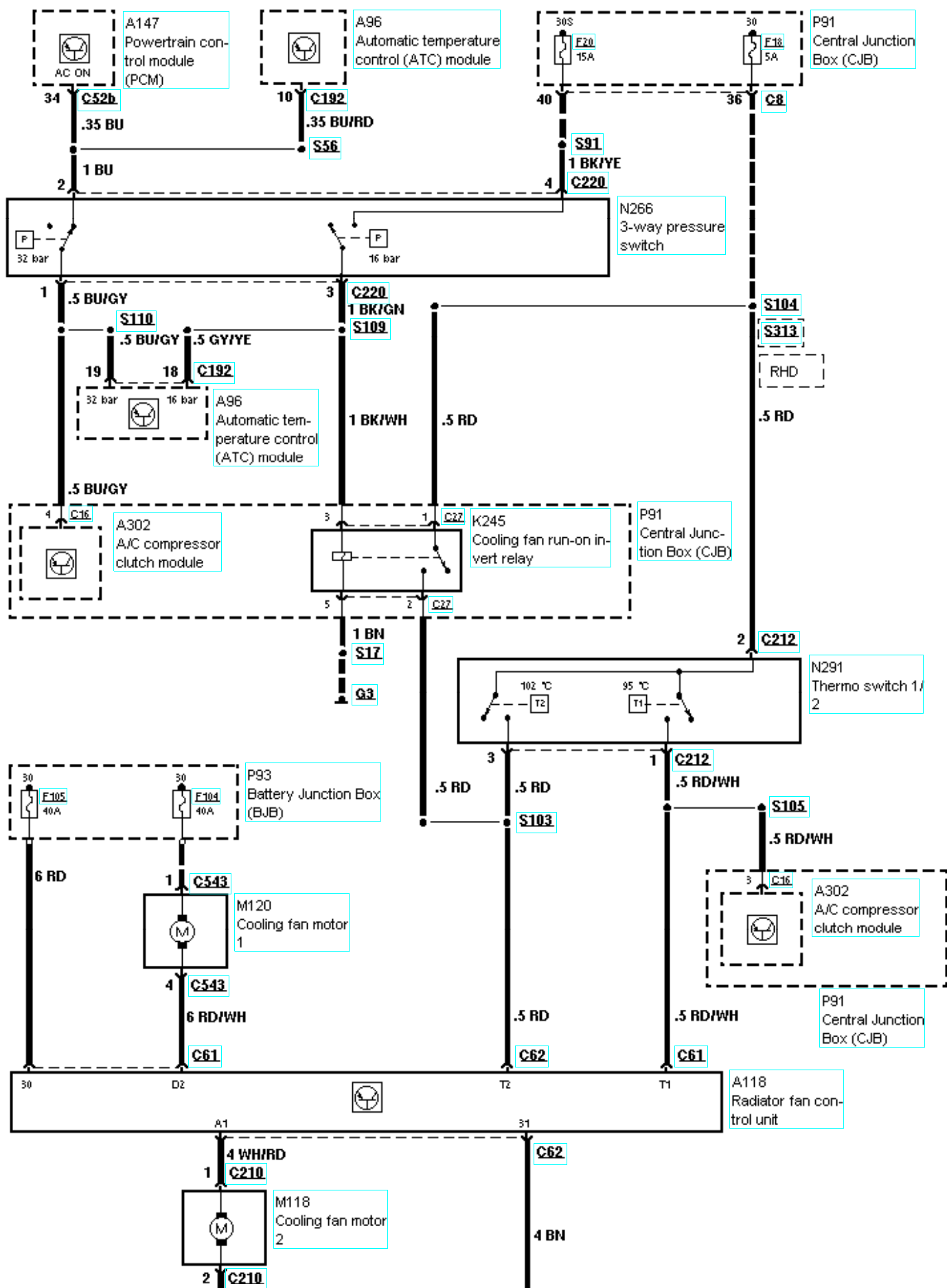

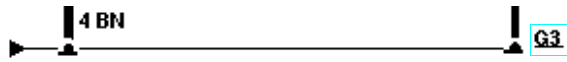

412-03A-00-038, Air Conditioning, Air conditioning with ATC module, 1,9 TDI unit injector engine, except 96kW engine, as of 11/2001

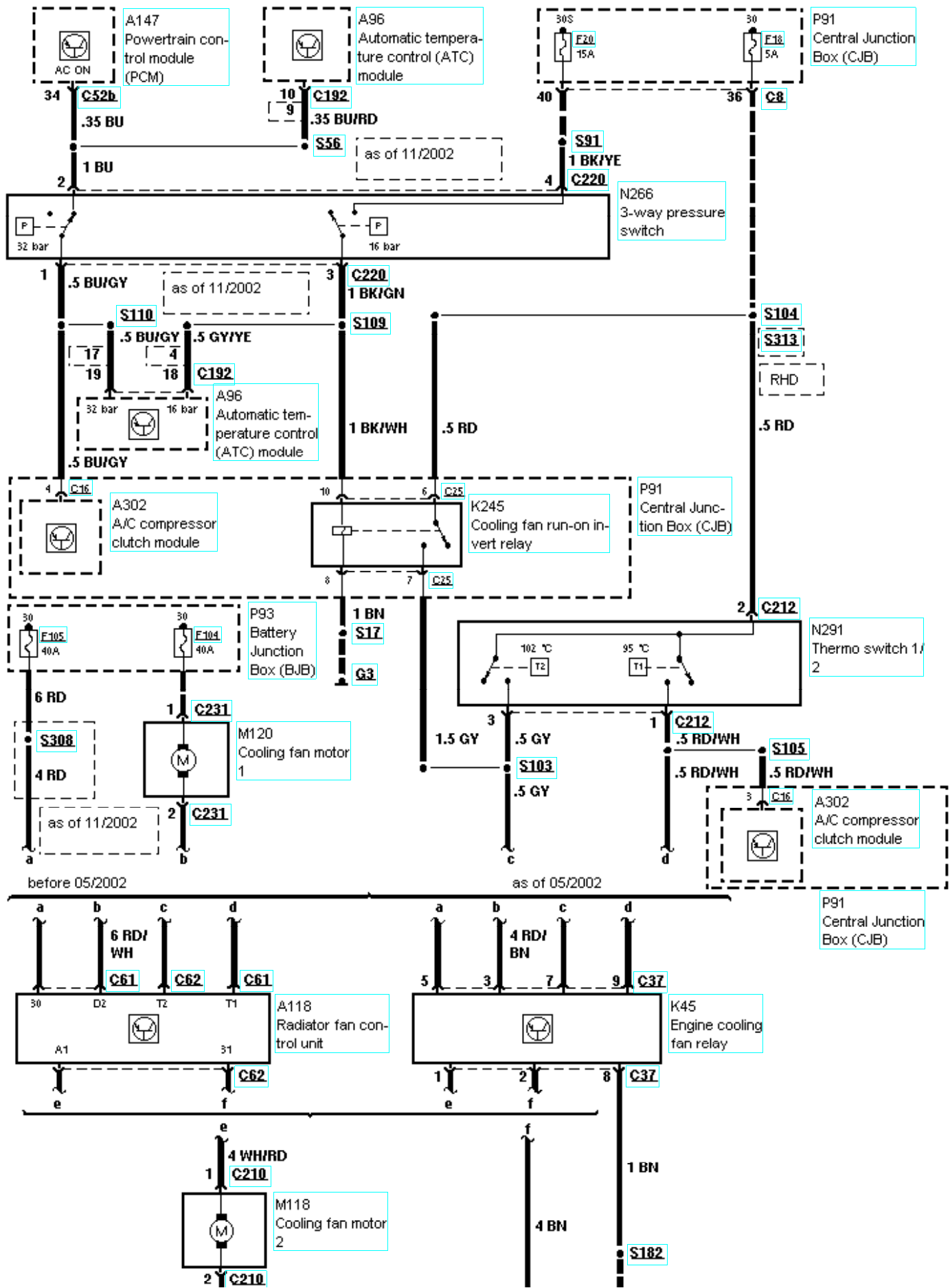

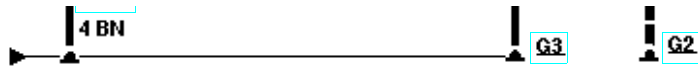

412-03A-00-039, Air Conditioning, Air conditioning with ATC module, 1,9 TDI unit injector engine, 96kW engine

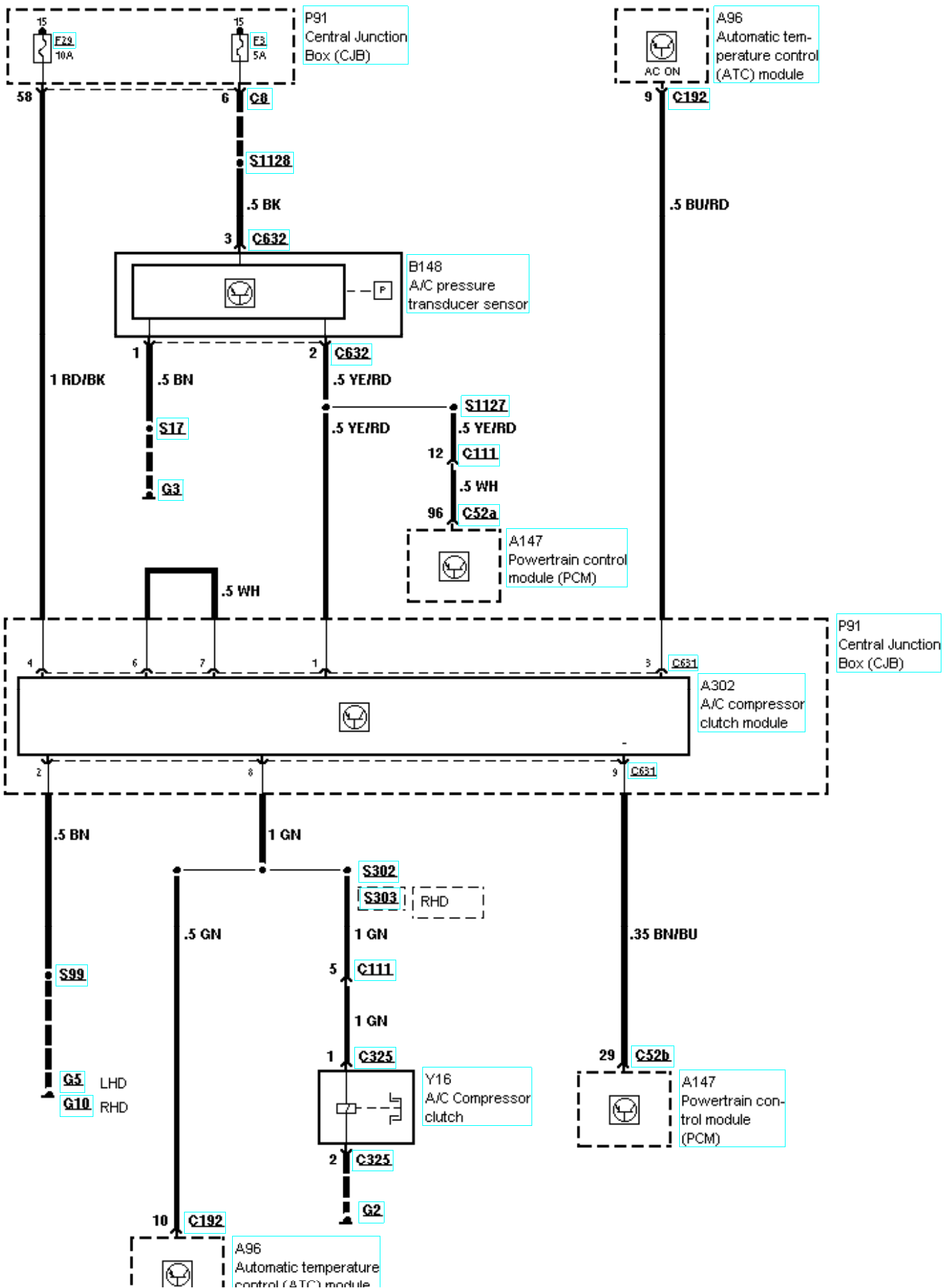

412-03A-00-040, Air Conditioning, Air conditioning with ATC module, 1,9 TDI unit injector engine, 96kW engine

