

---

419-01B-00-001, Anti-Theft - Passive, 2.0L DOHC/2.3L DOHC-16V, before 05/2002

---

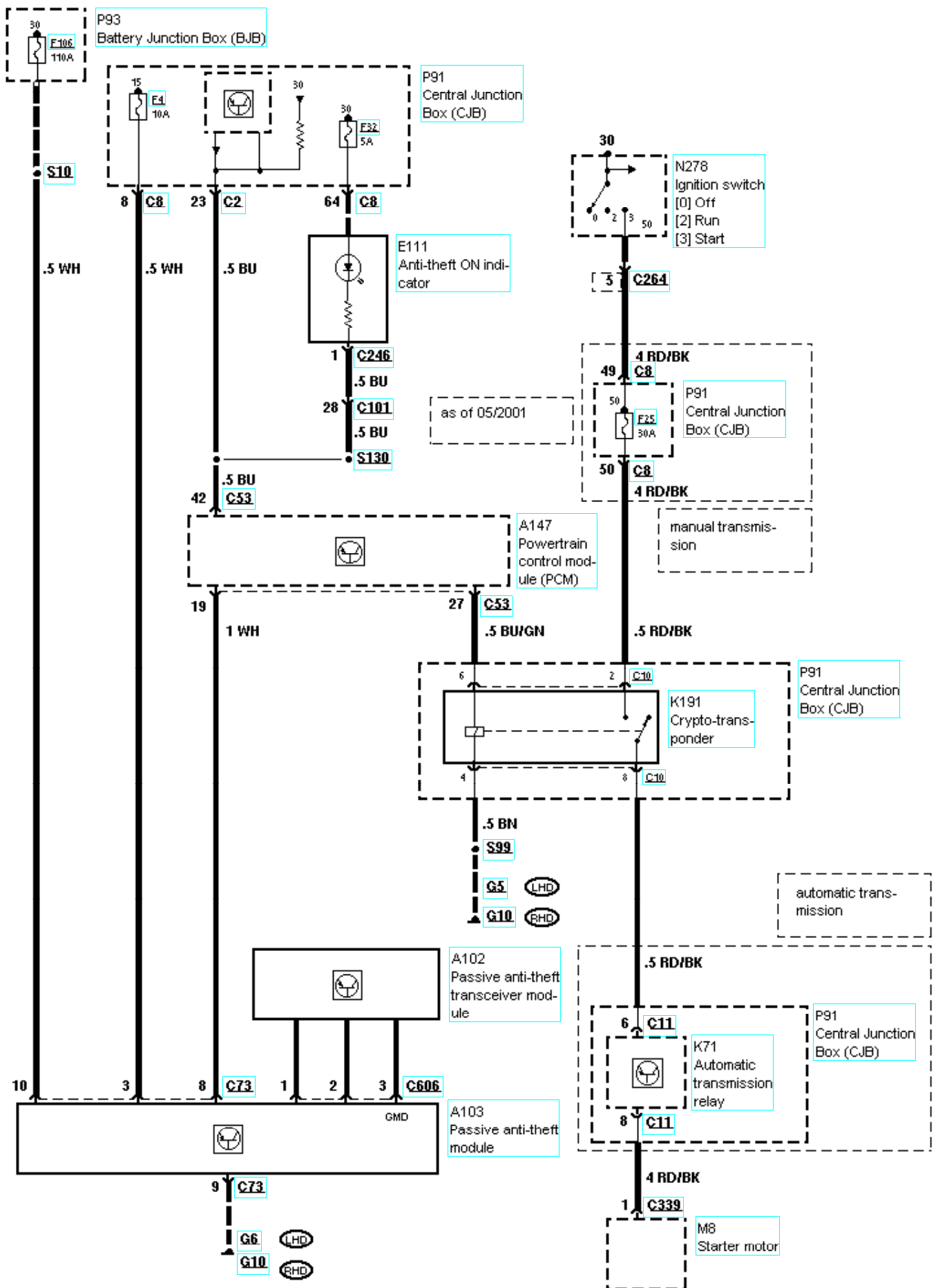

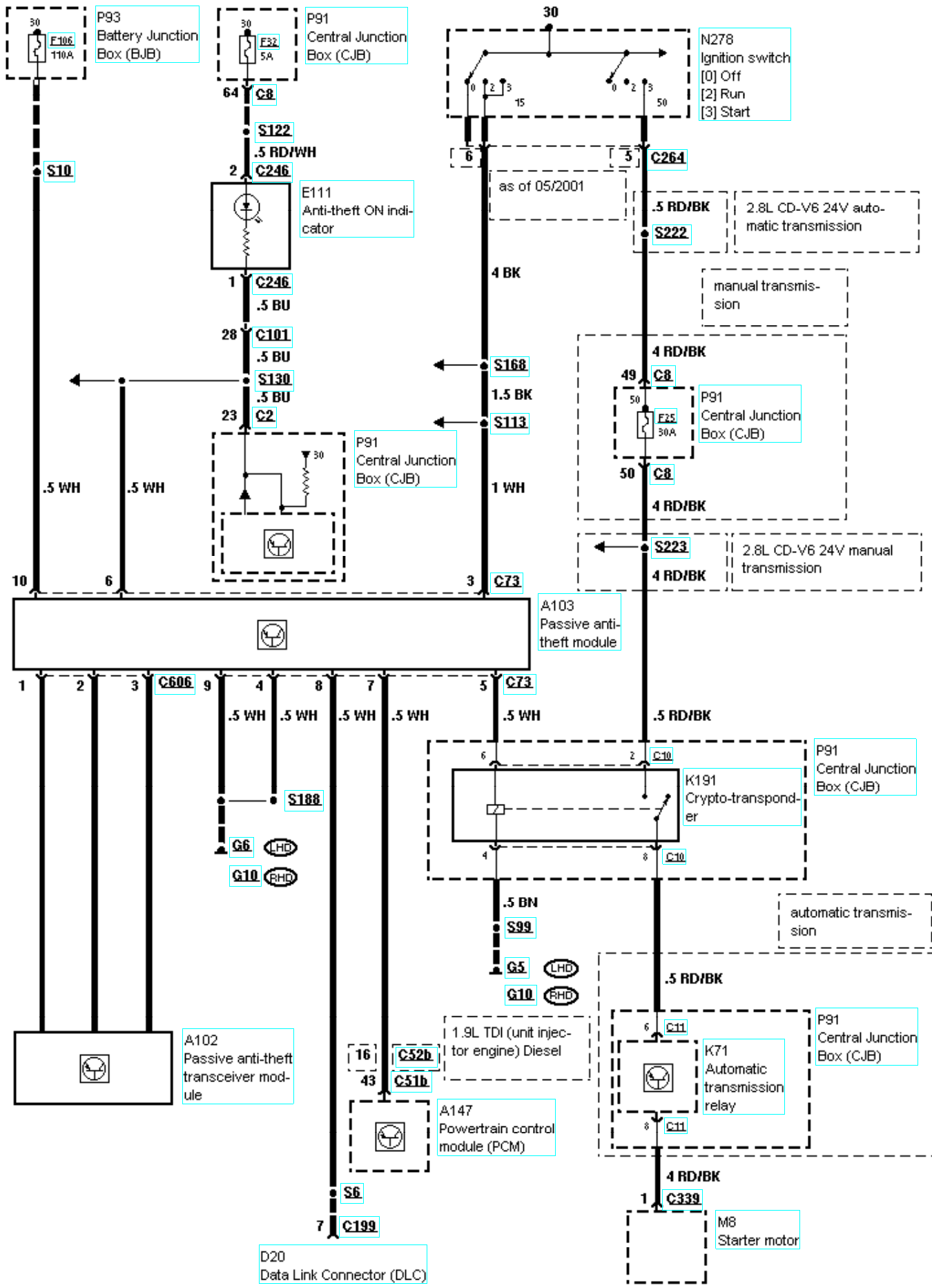

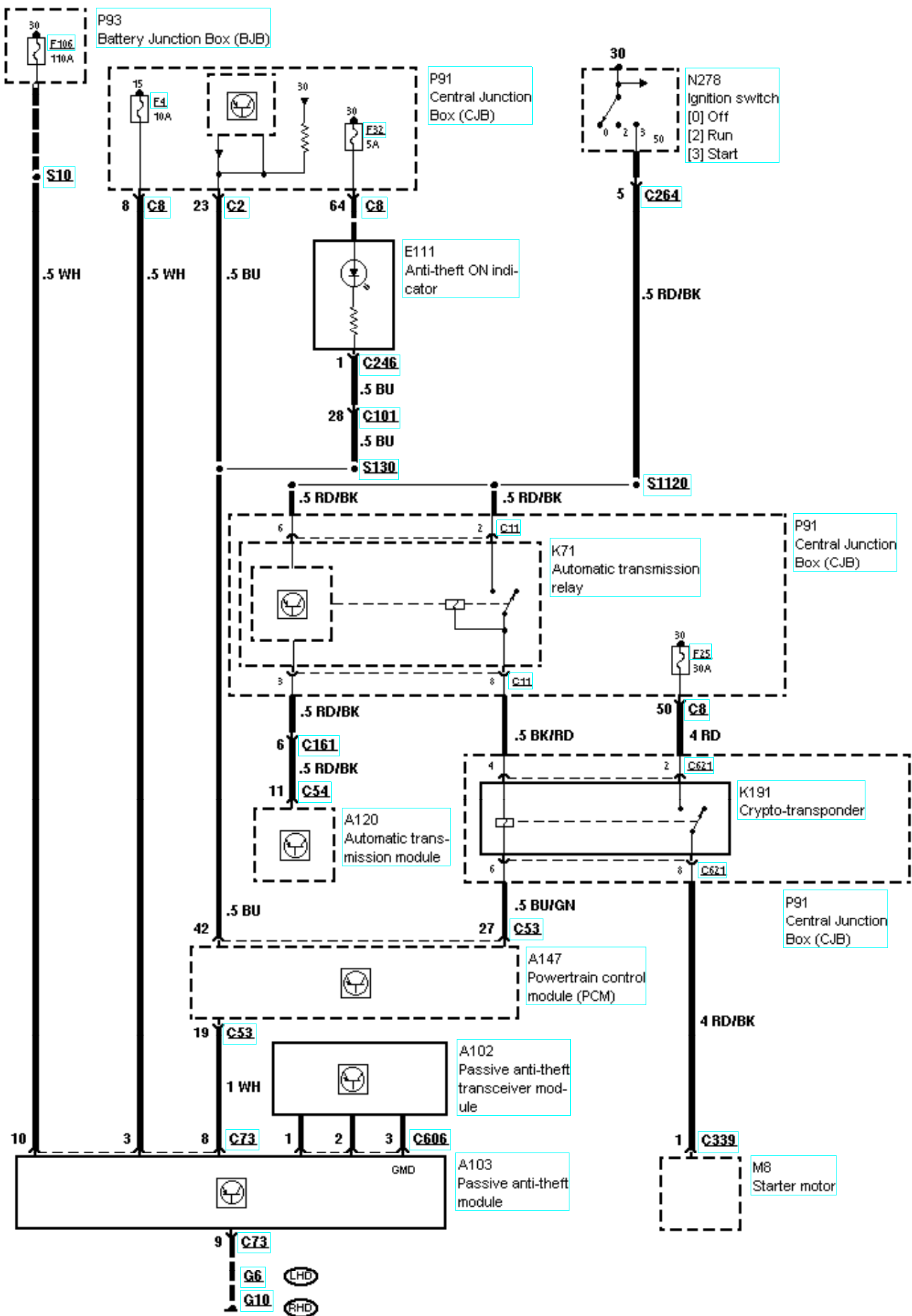

---

419-01B-00-004, Anti-Theft - Passive, 2.0L DOHC/2.3L DOHC-16V, as of 05/2002, manual transmission

---

